



Hinges

The Right Collection

Good-Better-Best solutions

State of the art technology

Design and functionality

Hinges are still the most effective way of articulating a cabinet door. With 250 Million hinges per year, FGV is the leading hinge manufacturer in Europe. The range covers all levels of requirement from the most sophisticated to the entry level. Recent innovations in terms of functionality like controlled movement of the door closing via dampening are adding further end-consumer appeal to the FGV range. With Optima Click, MSSide-On and QSMini hinges, the range covers all cabinet applications. Genios, SlowMotion and OneTouch technologies round-up an unrivalled program.



Genios



The Hidden Power



Genios is the innovative technology developed and patented by FGV to control the movement of concealed hinges. Genios is a new way to dampen hinges, and not being located in the hinge arm or in the hinge box, but in the formerly empty space underneath the mounting plate, this astute position generates a wealth of benefits for the industry and for end-consumers. Genios is available on Optima Click and on MSSide-On hinges.



Genios Video

Optima Click Genios

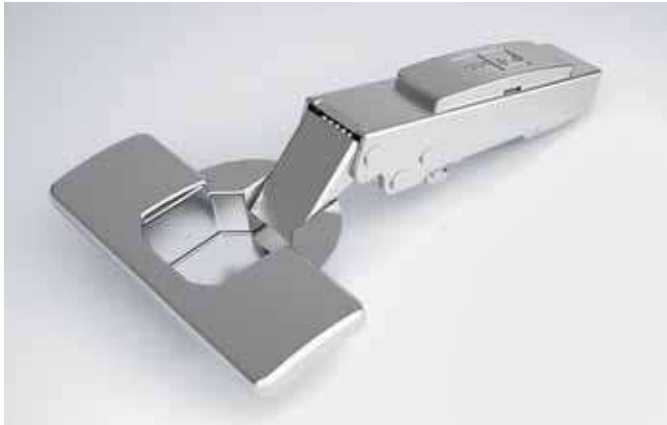

All the benefits from the Optima hinge range

Optima is the top range hinge of FGV. Its timeless design is completed with features like SafeClick fast assembly and One-Step 3D adjustment. Genios is resetting the agenda on integral damped hinges.

A technology to cover every application

Genios is available with all cranks and angled hinges, it works with framed doors, alu-frame doors and its extra flat arm works with inbuilt fridge configurations, as well as with English drawer situations. Thanks to One-Step-Anyway in and out adjustment, Genios copes with every door size and weight.



No modifications in the processing

Don't touch your machines! Don't go back to the drawing board. Keep your standard Optima hinge application and replace the current mounting plate by the Genios. Drilling depth, overlay and opening angles are unchanged. Genios doesn't require special solutions. It works with extra thin panels from 16mm to 30mm door thickness without any change in your applications.

Integral solution or add-on: your choice!

The mounting plate can come pre-assembled with the SlowMotion damper or ready for add-on. Choose the number of damped hinges easily to fit door size and weight. Choose your marketing option of the damping feature: integral or add-on.



Ms Slide-On Genios

An affordable solution

MS Slide-On hinges are a part of the world's leading volume manufacturer of quality hinges. Over 30 million cabinets are equipped year on year by this hinge range. One hundred million hinges are produced in Veduggio on the latest automatic equipment.

A quality solution

MS Slide-On hinges from FGV are easy to use. They are all certified to the highest quality standards in terms of performance and longevity and are guaranteed for 80.000 cycles during their lifetime. The range covers all applications, including corner solutions.



Adjustable impact

The damper is very powerful to cope with large and heavy doors. Nonetheless, the strength can be adjusted to smaller and lighter doors. The regulation can be made, adjusting the screw on the back of the damping housing. Not 100% or 0%, but a real progressive adjustment. A clear advantage for an overall very affordable solution.

Pre-mounted or retrofit

The product range is available with the damper pre-mounted into the mounting plate or as a retrofit able add-on solution, opening whole new perspectives for production and marketing. Stock holding is simplified, for manufacturer and for hardware dealer. Sales margins can be optimised with separate sales.



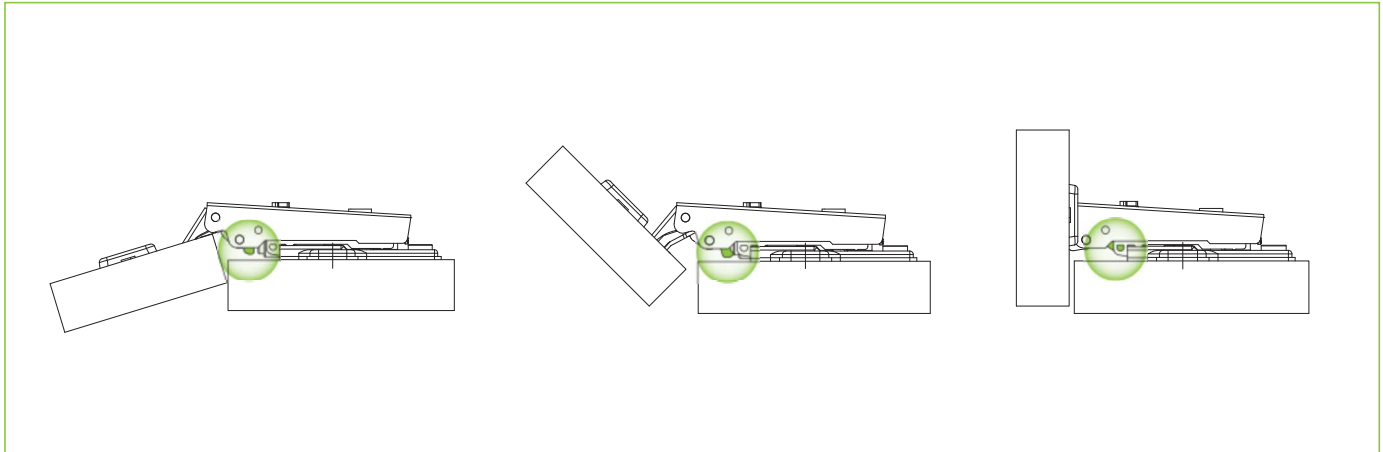

Simple and ingenious

Putting the damper into the least problematic zone of a hinge, namely under the mounting plate, is simply a genial design solution. No bulky hinge box – no protruding hinge arm. Simply Genios!

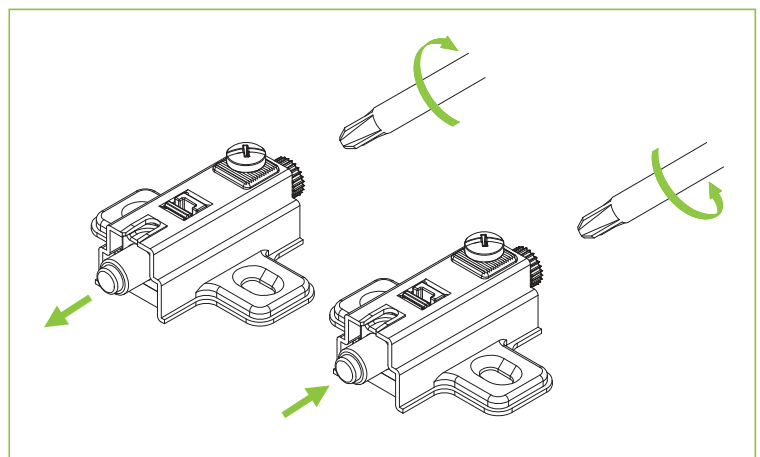
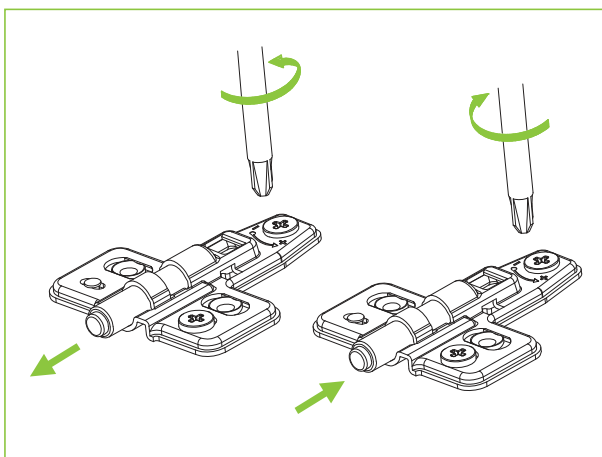

Strong and adjustable

The damper is very powerful to cope with large and heavy doors. Nonetheless, the strength can be adjusted to smaller and lighter doors. It is even possible to use the damper only on certain hinges. Simply Genios!

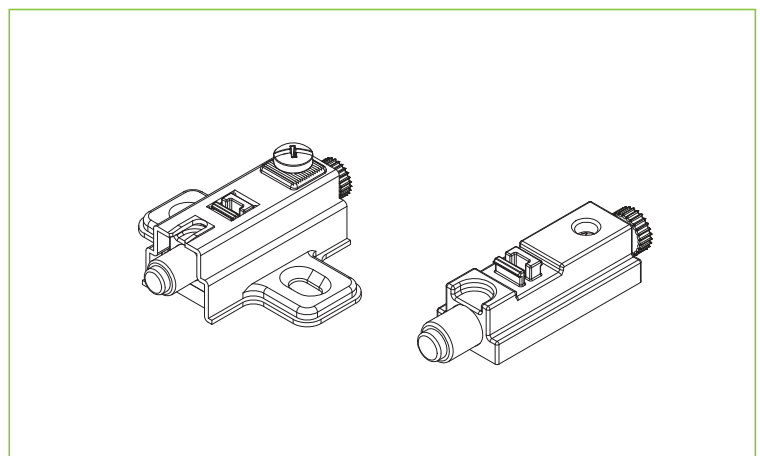
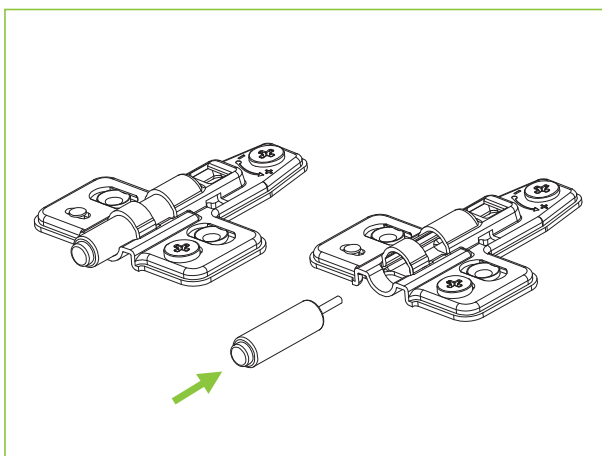

Integral or add-on

The product range is available with the damper pre-mounted into the mounting plate or as a retrofittable add-on solution, opening whole new perspectives for production and marketing. Simply Genios!

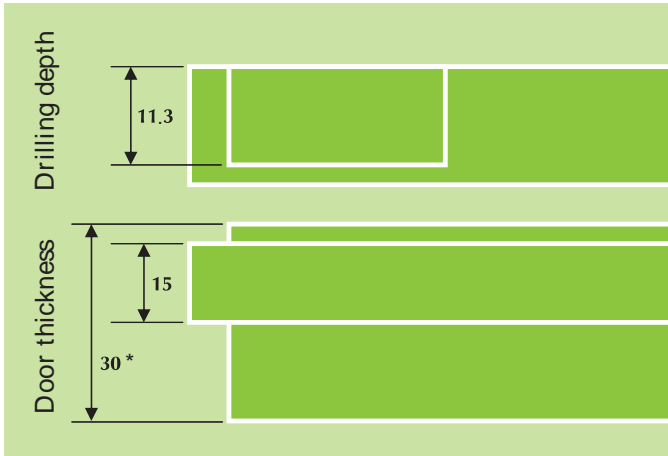

* 30mm in version MT / 26mm in standard

Keep your application and convert without hassle to Genios technology

Thin or thick doors, light or heavy doors, Genios covers them all.

Thanks to the possibility to choose the number of numbers and to fine-tune the adjustment with One-Step-Anyway feature, there is no application Genios doesn't cover.

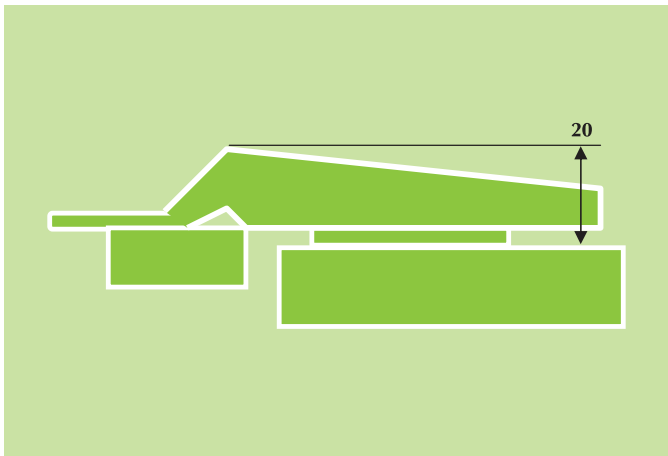

Genios: the hidden power

Placed under the previously empty space under the central hump of the mounting plate, the SlowMotion damper has no incidence on look or external dimensions of the hinge. Strength and adjustability are combined to deliver hidden force and majestic closing.

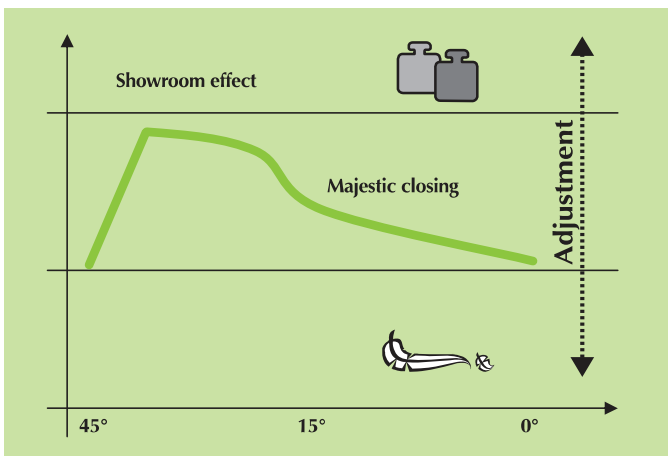

Affordable

No change in process, no need for costly thick doors, no "inbuilt gas-factory" in this rational and ingenious technology. And the choice between integral and add-on solution. All ingredients are together for the most affordable solution from the European leader of concealed hinges with an installed capacity of more than 250 Mio hinges in Veduggio.

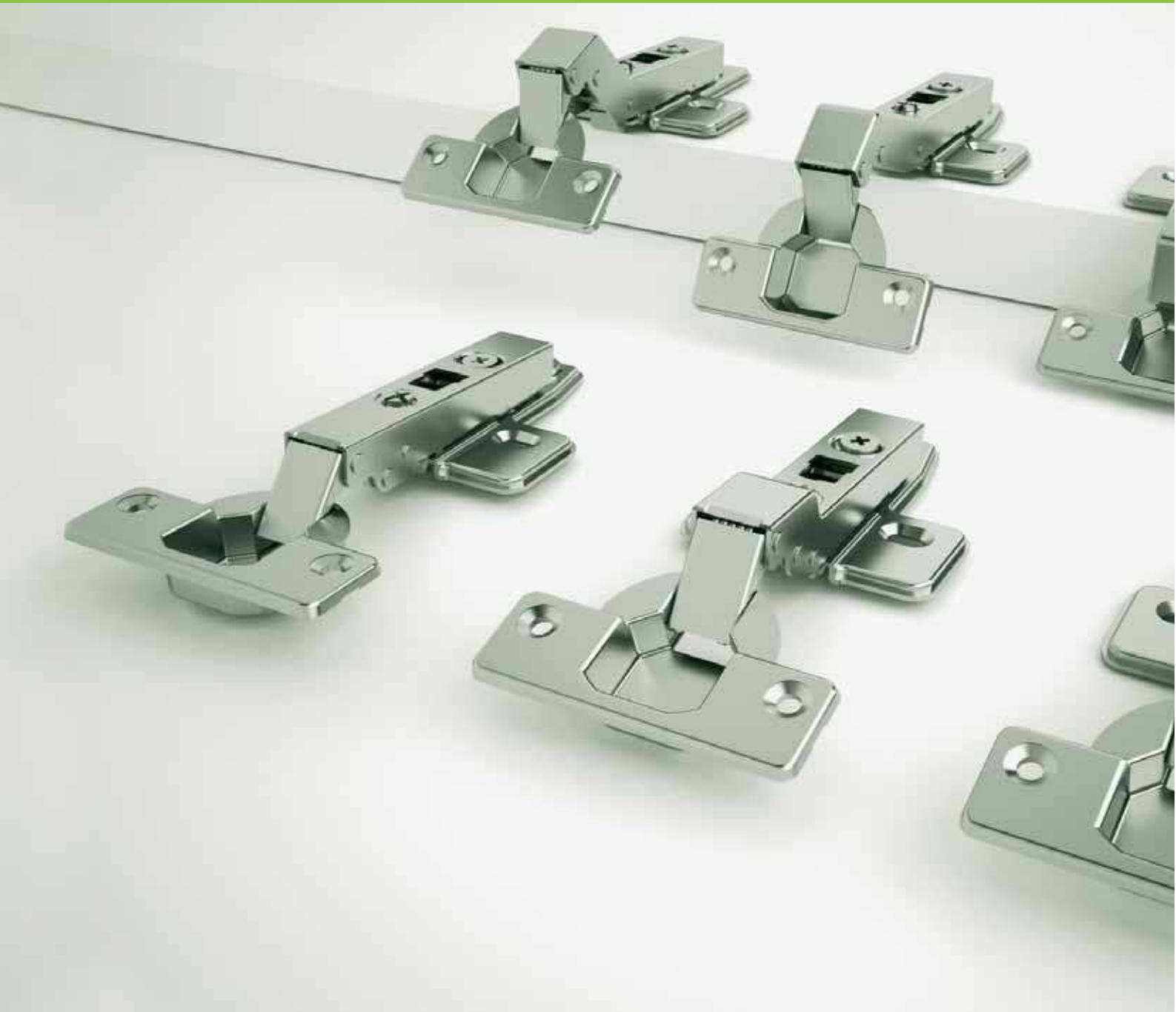

Hinges Index

Optima Click	18-59
MS Side-On	60-107
QS Mini	108-127
SlowMotion accessories	129-147
Alfa	130
Delta	134
Zitto	138
OneTouch	142
Appendix	
Pictograms	166-167

The variety of hinges and mounting plates that Formenti & Giovenzana offers is certainly one of the most complete.

For every hinge or mounting plate it is possible to select the fixing system most suitable to the need.

- Selftapping and euro screw: the standard
- Dowel: for industrial insertion
- Velofix and X-Pando dowel: to reduce the assembly time
- Centra and Zip: for no-tool mounting



Optima Click

The right look

Designed to last

One-Step 3D adjustment

Safe rapid fixing

Genios compatible

Option OneTouch

Complete system

The Optima Click hinge represents the premium offering in the FGV hinge program with improved, elegant & timeless design and some unique functional features. An aesthetic and functionally convincing hinge, with a straight and modern look, emphasized by the possibility of customization with a logo. All the adjustments are immediate, allowing to find the door's correct position in one step. Optima hinges are available with the whole array of cup-fixing solutions, including the no-tool Centra system. To keep the door movement under control and providing a silent closing Optima hinges are available in Genios configuration, and compatible with SlowMotion add-on damper solutions as well.

Optima Click

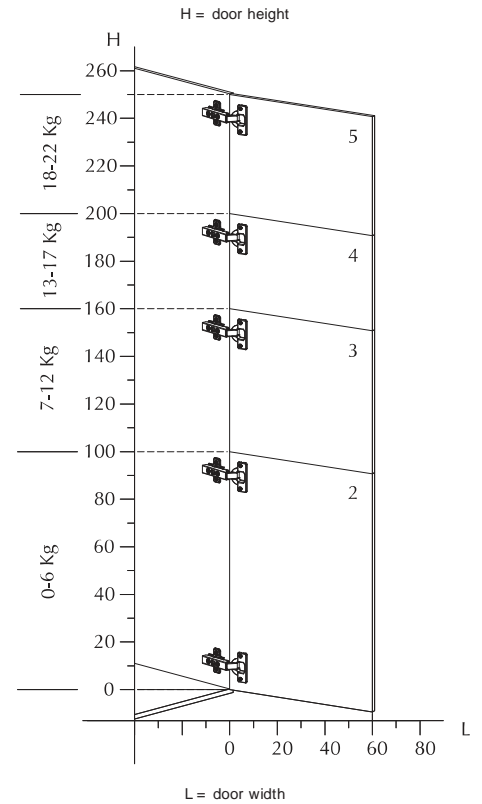

Mounting System



1 Place the front part of the hinge on the front side of the mounting plate.



2 Rotate the arm of the hinge.



3 Press down the rear part of the hinge to Click on.

Adjusting System

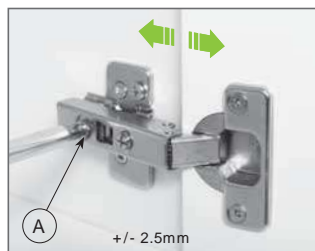

Depth adjustment
Acting on the "A" screw it is possible to adjust the distance between the side of the cabinet and the door.

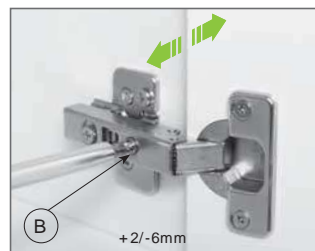

Independent side adjustment
Acting on the "B" screw it is possible to change the amount of the door covering on the side of the cabinet.

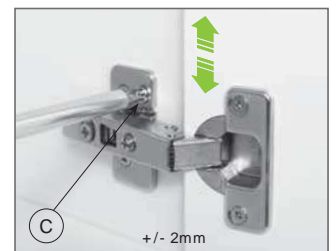

Vertical adjustment
Acting on the "C" screw of the mounting plate it is possible to adjust the door vertically.

INDEX

OPENING 110°		Summary table	p. 22
		Product detail	p. 26
OPENING 125°		Summary table	p. 22
		Product detail	p. 28
OPENING 175°		Summary table	p. 22
		Product detail	p. 30
FOR THICK DOORS 95° Ø35		Summary table	p. 22
		Product detail	p. 32
FOR CORNER DOORS 110°		Summary table	p. 22
		Product detail	p. 34
FOR CORNER CABINET 90°		Summary table	p. 22
		Product detail	p. 36

SPECIAL SOLUTIONS

FOR DOORS WITH ALUMINIUM FRAME 105°		Summary table	p. 25
		Product detail	p. 38
FOR THICK DOORS 90° Ø40		Summary table	p. 25
		Product detail	p. 42
ZIP FIXING SYSTEM		Summary table	p. 25

Cup hole distance 48x6mm

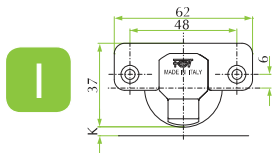

OPENING 110°



Crank 0		p. 26	p. 26	p. 26	p. 26	p. 26	p. 26
Crank 8		p. 26	p. 26	p. 26	p. 26	p. 26	p. 26
Crank 15		p. 26	p. 26	p. 26	p. 26	p. 26	p. 26

OPENING 125°



Crank 0		p. 28	p. 28	p. 28	p. 28	p. 28	p. 28
Crank 8		p. 28	p. 28	p. 28	p. 28	p. 28	p. 28

OPENING 175°



Crank 0		p. 30	p. 30	p. 30	p. 30	p. 30	
Crank 8		p. 30	p. 30	p. 30	p. 30	p. 30	

FOR THICK DOORS OPENING 95° Ø35



Crank 0		p. 32	p. 32	p. 32	p. 32		
Crank 8		p. 32	p. 32	p. 32	p. 32		
Crank 15		p. 32	p. 32	p. 32	p. 32		

FOR CORNER DOORS 110°



Angle 24°±30°		p. 34	p. 34	p. 34	p. 34	p. 34	p. 34
Angle 45°		p. 34	p. 34	p. 34	p. 34	p. 34	p. 34
Angle 90°		p. 34	p. 34	p. 34	p. 34	p. 34	p. 34

FOR CORNER CABINET



		p. 36	p. 36	p. 36	p. 36	p. 36	
--	--	-------	-------	-------	-------	-------	--



SELF TAPPING SCREW

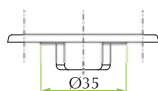

EURO SCREW

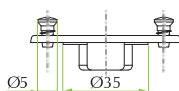

DOWEL

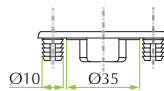

VELOFIX DOWEL

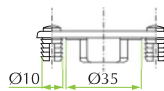

X-PANDO DOWEL

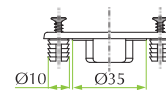

CENTRA

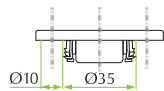

Cup hole distance
45x9.5mm

A

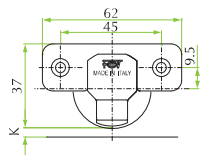

OPENING 110°



Crank 0		p. 26	p. 26	p. 26	p. 26	p. 26	p. 26
Crank 8		p. 26	p. 26	p. 26	p. 26	p. 26	p. 26
Crank 15		p. 26	p. 26	p. 26	p. 26	p. 26	p. 26

OPENING 125°



Crank 0		p. 28	p. 28	p. 28	p. 28	p. 28	p. 28
Crank 8		p. 28	p. 28	p. 28	p. 28	p. 28	p. 28

OPENING 175°



Crank 0		p. 30	p. 30	p. 30	p. 30	p. 30	
Crank 8		p. 30	p. 30	p. 30	p. 30	p. 30	

FOR THICK DOORS
OPENING 95° Ø35



Crank 0		p. 32	p. 32	p. 32	p. 32		
Crank 8		p. 32	p. 32	p. 32	p. 32		
Crank 15		p. 32	p. 32	p. 32	p. 32		

FOR CORNER DOORS 110°

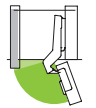

Angle 24°±30°		p. 34	p. 34	p. 34	p. 34	p. 34	p. 34
Angle 45°		p. 34	p. 34	p. 34	p. 34	p. 34	p. 34
Angle 90°		p. 34	p. 34	p. 34	p. 34	p. 34	p. 34

FOR CORNER CABINET

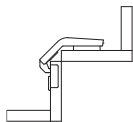

		p. 36	p. 36	p. 36	p. 36	p. 36	
--	--	-------	-------	-------	-------	-------	--



SELFTAPPING
SCREW

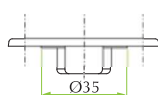

EURO
SCREW

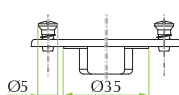

DOWEL

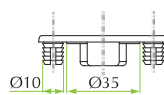

VELOFIX
DOWEL

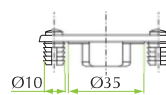

X-PANDO
DOWEL

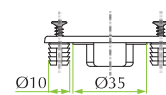

CENTRA

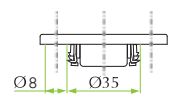

Cup hole distance
52x5.5mm

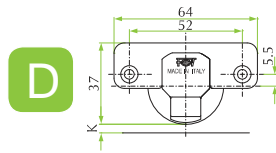

OPENING 110°



Crank 0		p. 26	p. 26	p. 26	p. 26	p. 26
Crank 8		p. 26	p. 26	p. 26	p. 26	p. 26
Crank 15		p. 26	p. 26	p. 26	p. 26	p. 26

OPENING 125°



Crank 0		p. 28	p. 28	p. 28	p. 28	p. 28
Crank 8		p. 28	p. 28	p. 28	p. 28	p. 28

OPENING 175°



Crank 0		p. 30	p. 30	p. 30	p. 30	p. 30
Crank 8		p. 30	p. 30	p. 30	p. 30	p. 30

FOR THICK DOORS
OPENING 95° Ø35



Crank 0		p. 32	p. 32	p. 32	p. 32	
Crank 8		p. 32	p. 32	p. 32	p. 32	
Crank 15		p. 32	p. 32	p. 32	p. 32	

FOR CORNER DOORS 110°



Angle 24°÷30°		p. 34	p. 34	p. 34	p. 34	p. 34
Angle 45°		p. 34	p. 34	p. 34	p. 34	p. 34
Angle 90°		p. 34	p. 34	p. 34	p. 34	p. 34

FOR CORNER CABINET

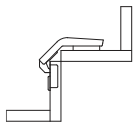

		p. 36	p. 36	p. 36	p. 36	p. 36
--	--	-------	-------	-------	-------	-------



SELF TAPPING
SCREW

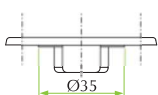

EURO
SCREW

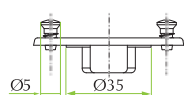

DOWEL

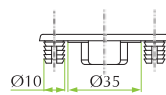

VELOFIX
DOWEL

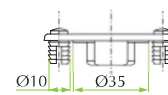

X-PANDO
DOWEL

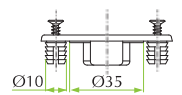

GROOVED PROFILE

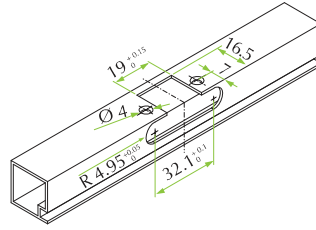

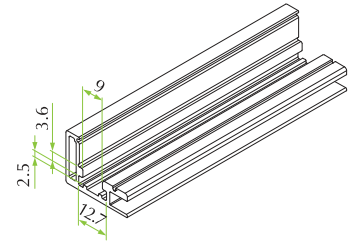

LOCK FIXING



FOR DOORS WITH ALUMINIUM FRAME 105°



Crank 0		p. 38	p. 40
Crank 8		p. 38	p. 40
Crank 15		p. 38	p. 40

CUP HOLE DISTANCE 52x7.5mm

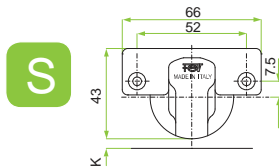

SELFTAPPING SCREW

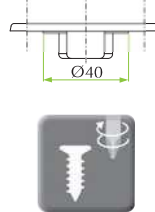



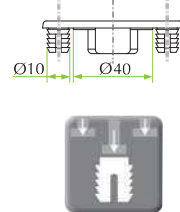

DOWEL



FOR THICK DOORS OPENING 90° Ø40



Crank 0		p. 42	p. 42
Crank 8		p. 42	p. 42
Crank 15		p. 44	p. 44
Crank 22		p. 44	p. 44

ZIP FIXING SYSTEM

The Zip dowels allow a no-tool mounting of the hinge.

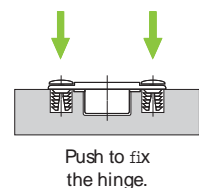
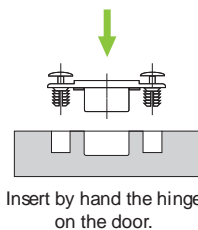

The hinges with Zip fixing system are available on demand. Please contact the FGV Customer Service.

Optima Click 110°



Technical specifications:

- Depth of the metal cup 11.3mm
- Cup diameter 35mm
- Opening 110° with (K) max 4mm and (T) max 18mm
- Possibility of door drilling (K) from 3 to 7 mm
- Thickness of the door (T) from 16 to 26 mm
- Genios, SlowMotion Alfa and OneTouch solutions

CRANK 0



CRANK 8



CRANK 15



I
A
D

51.XSH5.05.00.0 ●
51.XSH5.05.00.C ●
51.XSH5.05.00.B ●

51.XSH5.05.08.0 ●
51.XSH5.05.08.C ●
51.XSH5.05.08.B ●

51.XSH5.05.15.0 ●
51.XSH5.05.15.C ●
51.XSH5.05.15.B ●

Available with premounted selftapping screws



I
A
D

51.XSH6.05.00.M ●
51.XSH6.05.00.N ●
51.XSH6.05.00.E ●

51.XSH6.05.08.M ●
51.XSH6.05.08.N ●
51.XSH6.05.08.E ●

51.XSH6.05.15.M ●
51.XSH6.05.15.N ●
51.XSH6.05.15.E ●



I
A
D

51.XSH6.05.00.* ●
51.XSH6.05.00.S ●
51.XSH6.05.00.B ●

51.XSH6.05.08.* ●
51.XSH6.05.08.S ●
51.XSH6.05.08.B ●

51.XSH6.05.15.* ●
51.XSH6.05.15.S ●
51.XSH6.05.15.B ●

* 0 = dowels Ø10mm / D = dowels Ø8mm



I
A
D

51.XSH8.05.00.V ●
51.XSH8.05.00.U ●
51.XSH8.05.00.Z ●

51.XSH8.05.08.V ●
51.XSH8.05.08.U ●
51.XSH8.05.08.Z ●

51.XSH8.05.15.V ●
51.XSH8.05.15.U ●
51.XSH8.05.15.Z ●



I
A
D

51.XSH9.05.00.0 ●
51.XSH9.05.00.S ●
51.XSH9.05.00.B ●

51.XSH9.05.08.0 ●
51.XSH9.05.08.S ●
51.XSH9.05.08.B ●

51.XSH9.05.15.0 ●
51.XSH9.05.15.S ●
51.XSH9.05.15.B ●



I
A

51.XSHC.05.00.0
51.XSHC.05.00.0

51.XSHC.05.08.0
51.XSHC.05.08.0

51.XSHC.05.15.0
51.XSHC.05.15.0

● = G / Genios Solution

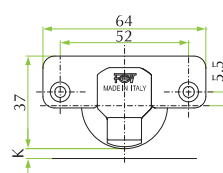
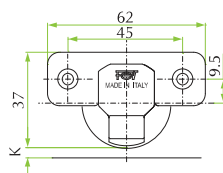
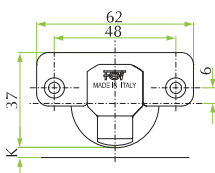

The mounting plates and fittings for this hinge series are shown from page 46 to page 59.

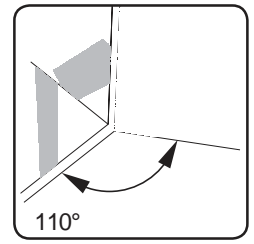
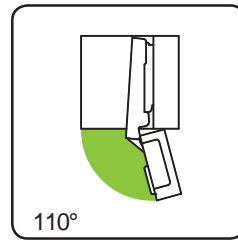

CRANK 0
For lay-on doors

CRANK 8
For partial lay-on doors

CRANK 15
For inset doors

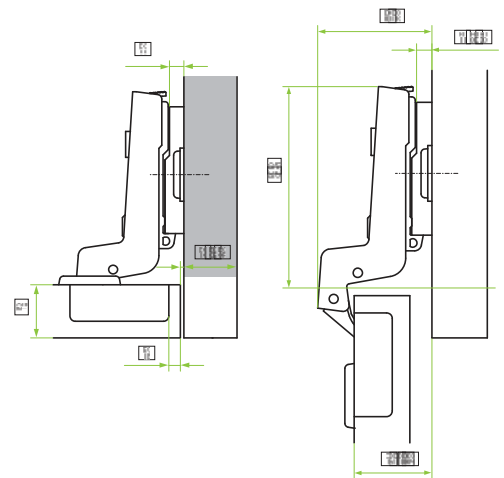
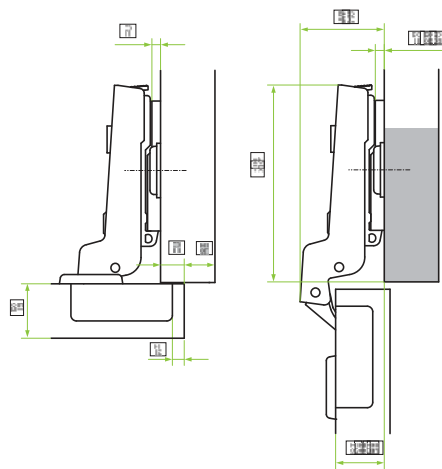
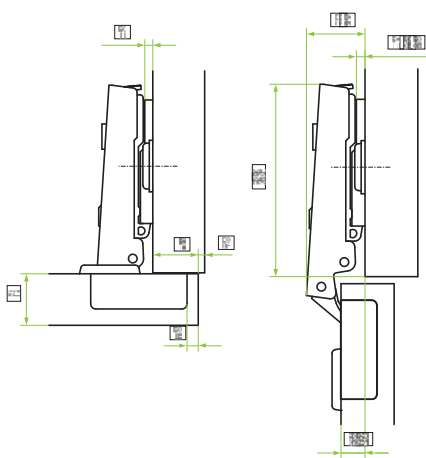

Overlay (C)	Drilling distance (K)						
	3	4	5	6	7		
19					2		
18				2			
17			2		4		
16		2		4			
15	2		4		6		
14		4		6			
13	4		6				
12		6					
11	6						Mounting plates (H)

Overlay (C)	Drilling distance (K)						
	3	4	5	6	7		
11					2		
10				2			
9			2		4		
8		2		4			
7	2		4		6		
6		4		6			
5	4		6				
4		6					
3	6						Mounting plates (H)

Overlay (C)	Drilling distance (K)						
	3	4	5	6	7		
0	2		4		6		
1		4		6			
2	4		6				
3		6					
4	6						
							Mounting plates (H)

Table to determine the minimum distance A so that a door with T thickness can open without protrusion from the cabinet and without interfering with adjacent doors.

T=	16	17	18	19	20	21	22	23	24	25	26
K=3 A=	0.55	0.75	1.10	1.45	1.80	2.40	3.10	3.90	4.70	6.70	6.50
K=4 A=	0.55	0.70	1.05	1.40	1.75	2.25	2.85	3.60	4.35	5.75	6.00
K=5 A=	0.53	0.70	1.00	1.35	1.65	2.10	2.65	3.30	4.00	4.75	5.55
K=6 A=	0.50	0.70	0.95	1.25	1.60	2.00	2.50	3.05	3.70	4.40	5.20
K=7 A=	0.50	0.65	0.85	1.20	1.55	1.90	2.35	2.85	3.45	4.10	4.80

Optim a Click 125°



Technical specifications:

- Depth of the metal cup 11.3mm
- Cup diameter 35mm
- Opening 125° with (K) max 4mm and (T) max 18mm
- Possibility of door drilling (K) from 3 to 5 mm
- Thickness of the door (T) from 16 a 26 mm
- OneTouch solutions

CRANK 0



CRANK 8



I
A
D

51.XKH5.M5.00.0
51.XKH5.M5.00.C
51.XKH5.M5.00.B

51.XKH5.M5.08.0
51.XKH5.M5.08.C
51.XKH5.M5.08.B

Available with premounted selftapping screws



I
A
D

51.XKH6.M5.00.M
51.XKH6.M5.00.N
51.XKH6.M5.00.E

51.XKH6.M5.08.M
51.XKH6.M5.08.N
51.XKH6.M5.08.E



I
A
D

51.XKH6.M5.00.*
51.XKH6.M5.00.S
51.XKH6.M5.00.B

51.XKH6.M5.08.*
51.XKH6.M5.08.S
51.XKH6.M5.08.B

* 0 = dowels Ø10mm / D = dowels Ø8mm



I
A
D

51.XKH8.M5.00.V
51.XKH8.M5.00.U
51.XKH8.M5.00.Z

51.XKH8.M5.08.V
51.XKH8.M5.08.U
51.XKH8.M5.08.Z



I
A
D

51.XKH9.M5.00.0
51.XKH9.M5.00.S
51.XKH9.M5.00.B

51.XKH9.M5.08.0
51.XKH9.M5.08.S
51.XKH9.M5.08.B



I
A

51.XKHC.05.00.0
51.XKHC.05.00.0

51.XKHC.05.08.0
51.XKHC.05.08.0

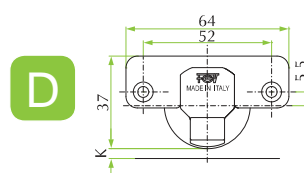
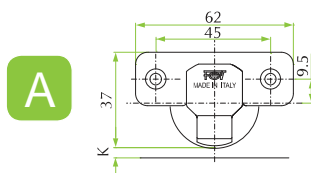
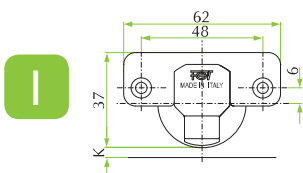

The mounting plates and fittings for this hinge series are shown from page 46 to page 59.

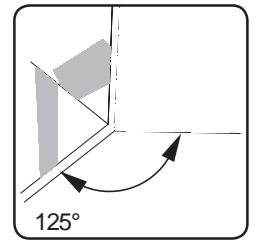
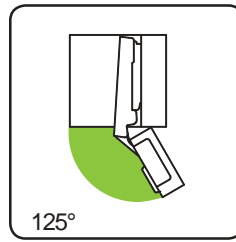

CRANK 0
For lay-on doors

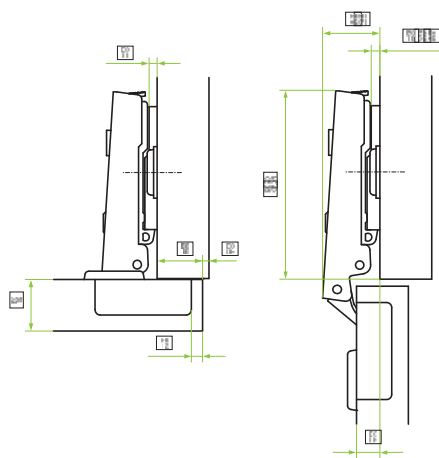

CRANK 8
For partial lay-on doors

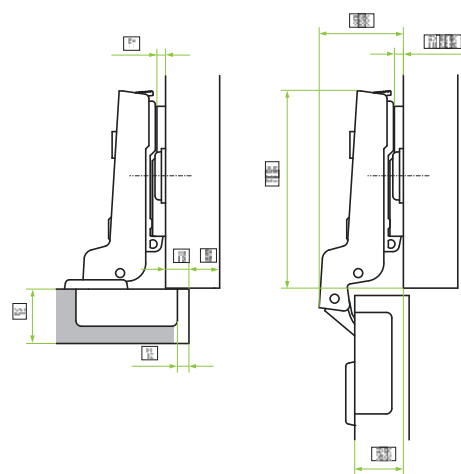

Overlay (C)	Drilling distance (K)							Mounting plates (H)
	3	4	5	6	7			
19					2			
18				2				
17			2	4				
16		2	4					
15	2		4	6				
14		4	6					
13	4		6					
12		6						
11	6							

Overlay (C)	Drilling distance (K)							Mounting plates (H)
	3	4	5	6	7			
11					2			
10				2				
9			2	4				
8		2	4					
7	2		4	6				
6		4	6					
5	4		6					
4		6						
3	6							

Table to determinate the minimum distance A so that a door with T thickness can open without protrusion from the cabinet and without interfering with adjacent doors.

T=	16	17	18	19	20	21	22	23	24	25	26
K=3 A=	0.90	1.40	1.90	2.40	3.00	3.60	4.25	4.90	5.55	6.20	6.80
K=4 A=	0.85	1.25	1.75	2.25	2.75	3.35	4.00	4.65	5.30	5.95	6.60
K=5 A=	0.80	1.10	1.60	2.10	2.55	3.15	3.75	4.45	5.05	5.70	6.35

Optima Click 175°



Technical specifications:

- Depth of the metal cup 11.3mm
- Cup diameter 35mm
- Opening 175°
- Possibility of door drilling (K) from 3 to 7 mm
- Thickness of the door (T) from 16 to 26 mm
- SlowMotion Delta add-on damper solutions

CRANK 0



CRANK 8



I
A
D

51.XWH5.M5.00.0

51.XWH5.M5.00.C

51.XWH5.M5.00.B

Available with premounted selftapping screws

51.XWH5.M5.08.0

51.XWH5.M5.08.C

51.XWH5.M5.08.B



I
A
D

51.XWH6.M5.00.M

51.XWH6.M5.00.N

51.XWH6.M5.00.E

51.XWH6.M5.08.M

51.XWH6.M5.08.N

51.XWH6.M5.08.E



I
A
D

51.XWH6.M5.00.*

51.XWH6.M5.00.S

51.XWH6.M5.00.B

* 0 = dowels Ø10mm / D = dowels Ø8mm

51.XWH6.M5.08.*

51.XWH6.M5.08.S

51.XWH6.M5.08.B



I
A
D

51.XWH8.M5.00.V

51.XWH8.M5.00.U

51.XWH8.M5.00.Z

51.XWH8.M5.08.V

51.XWH8.M5.08.U

51.XWH8.M5.08.Z



I
A
D

51.XWH9.M5.00.0

51.XWH9.M5.00.S

51.XWH9.M5.00.B

51.XWH9.M5.08.0

51.XWH9.M5.08.S

51.XWH9.M5.08.B

I

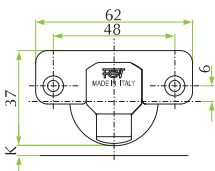

A

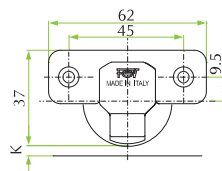

D

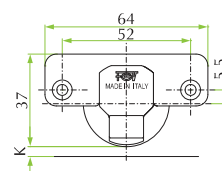

The mounting plates and fittings for this hinge series are shown from page 46 to page 59.

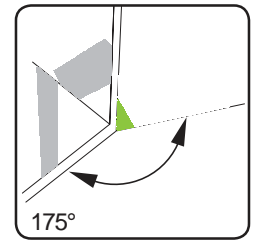
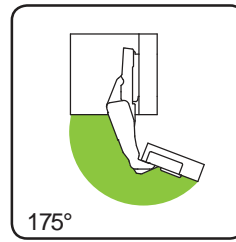

CRANK 0
For lay-on doors

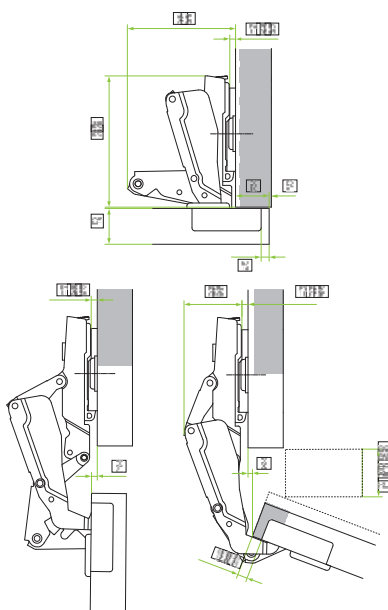

Overlay (C)	Drilling distance (K)						
	3	4	5	6	7		
19					2		
18				2			
17			2		4		
16		2		4			
15	2		4		6		
14		4		6			
13	4		6				
12		6					
11	6						Mounting plates (H)

CRANK 8
For partial lay-on doors

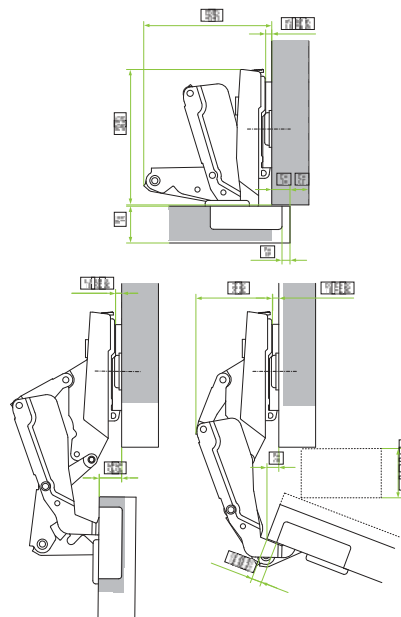

Overlay (C)	Drilling distance (K)						
	3	4	5	6	7		
11					2		
10				2			
9			2		4		
8		2		4			
7	2		4		6		
6		4		6			
5	4		6				
4		6					
3	6						Mounting plates (H)

Table to determinate the minimum distance A so that a door with T thickness can open without protrusion from the cabinet and without interfering with adjacent doors.

T=	16	17	18	19	20	21	22	23	24	25	26
K=3 A=	0.00	0.00	0.00	0.00	0.00	0.00	0.20	0.55	6.80	8.10	13.55
K=4 A=	0.00	0.00	0.00	0.00	0.00	0.05	0.30	3.50	5.85	7.25	12.55
K=5 A=	0.00	0.00	0.00	0.00	0.00	0.05	0.30	3.55	4.90	6.25	11.55
K=6 A=	0.00	0.00	0.00	0.00	0.00	0.05	0.40	3.00	3.90	5.25	10.55
K=7 A=	0.00	0.00	0.00	0.00	0.00	0.05	1.20	2.20	3.15	4.25	9.55

Optima Click 95° Ø35 for thick doors



Technical specifications:

- Depth of the metal cup 12.3mm
- Cup diameter 35mm
- Opening 95°
- Possibility of door drilling (K) from 3 to 7 mm
- Thickness of the door (T) from 16 to 30 mm
- Available only Genios solutions

CRANK 0



CRANK 8



CRANK 15



I
A
D

51.XZH5.05.00.0 ●
51.XZH5.05.00.C ●
51.XZH5.05.00.B ●

51.XZH5.05.08.0 ●
51.XZH5.05.08.C ●
51.XZH5.05.08.B ●

51.XZH5.05.15.0 ●
51.XZH5.05.15.C ●
51.XZH5.05.15.B ●

Available with premounted selftapping screws



I
A
D

51.XZH6.05.00.M ●
51.XZH6.05.00.N ●
51.XZH6.05.00.E ●

51.XZH6.05.08.M ●
51.XZH6.05.08.N ●
51.XZH6.05.08.E ●

51.XZH6.05.15.M ●
51.XZH6.05.15.N ●
51.XZH6.05.15.E ●



I
A
D

51.XZH6.05.00.* ●
51.XZH6.05.00.S ●
51.XZH6.05.00.B ●

51.XZH6.05.08.* ●
51.XZH6.05.08.S ●
51.XZH6.05.08.B ●

51.XZH6.05.15.* ●
51.XZH6.05.15.S ●
51.XZH6.05.15.B ●

* 0 = dowels Ø10mm / D = dowels Ø8mm



I
A
D

51.XZH8.05.00.V ●
51.XZH8.05.00.U ●
51.XZH8.05.00.Z ●

51.XZH8.05.08.V ●
51.XZH8.05.08.U ●
51.XZH8.05.08.Z ●

51.XZH8.05.15.V ●
51.XZH8.05.15.U ●
51.XZH8.05.15.Z ●

● = G / Genios Solution

I

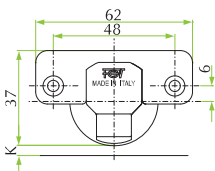

A

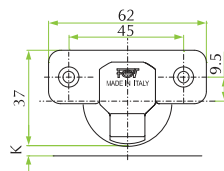

D

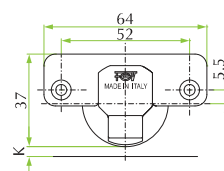

The mounting plates and fittings for this hinge series are shown from page 46 to page 59.

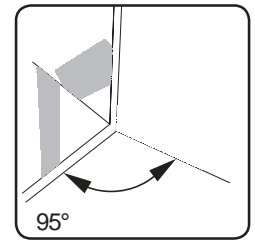
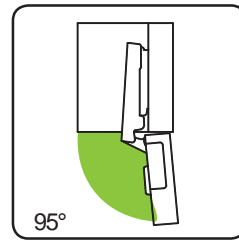

CRANK 0
For lay-on doors

CRANK 8
For partial lay-on doors

CRANK 15
For inset doors

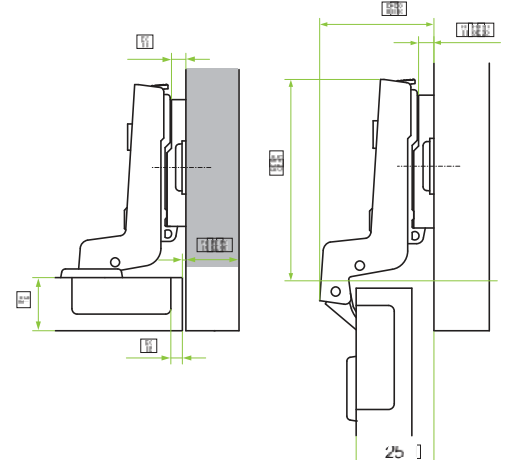
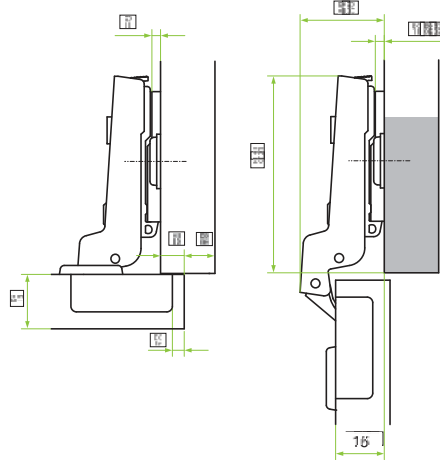
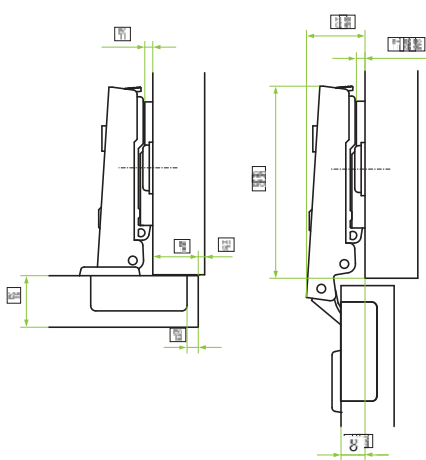

		Drilling distance (K)						
		3	4	5	6	7		
Overlay (C)	19			0	2			
	18		0	2				
	17	0	2	4				
	16	2	4					
	15	4	6					
	14	6						
	13	8						
	12	10						
	11	6						Mounting plates (H)

		Drilling distance (K)						
		3	4	5	6	7		
Overlay (C)	11			0	2			
	10		0	2				
	9	0	2	4				
	8	2	4					
	7	4	6					
	6	6						
	5	8						
	4	10						
	11	6						Mounting plates (H)

		Drilling distance (K)						
		3	4	5	6	7		
Overlay (C)	0	2	4	6				
	1	4	6					
	2	6						
	3							
	4							
								Mounting plates (H)

Table to determine the minimum distance A so that a door with T thickness can open without protrusion from the cabinet and without interfering with adjacent doors.

T=	16	17	18	19	20	21	22	23	24	25	26	27	28	29	30
K=3 A=	0.00	0.15	0.35	0.50	0.70	0.85	1.15	1.65	2.55	3.40	4.30	5.20	6.15	7.10	8.00
K=4 A=	0.00	0.15	0.30	0.50	0.65	0.85	1.10	1.40	2.10	2.90	3.80	4.65	5.50	6.45	7.40
K=5 A=	0.00	0.15	0.30	0.50	0.65	0.80	1.00	1.35	1.75	2.50	3.30	4.15	5.00	5.90	6.75
K=6 A=	0.00	0.10	0.30	0.45	0.65	0.80	1.00	1.30	1.65	2.15	2.90	3.65	4.50	5.40	6.05
K=7 A=	0.00	0.10	0.30	0.45	0.60	0.80	0.95	1.25	1.60	1.90	2.55	3.30	4.05	4.90	5.75

Optima Click 110° for corner doors



Technical specifications:

- Depth of the metal cup 11.3mm
- Cup diameter 35mm
- Opening 110°
- Possibility of door drilling (K) from 3 to 7 mm
- Thickness of the door (T) from 16 to 26 mm
- Genios and OneTouch solutions

ANGLE 24°÷30°



ANGLE 45°



ANGLE 90°



I
A
D

51.XH85.05.30.0 ●
51.XH85.05.30.C ●
51.XH85.05.30.B ●

51.XH85.05.45.0 ●
51.XH85.05.45.C ●
51.XH85.05.45.B ●

51.XH85.M5.90.0 ●
51.XH85.M5.90.C ●
51.XH85.M5.90.B ●

Available with premounted selftapping screws



I
A
D

51.XH86.05.30.M ●
51.XH86.05.30.N ●
51.XH86.05.30.E ●

51.XH86.05.45.M ●
51.XH86.05.45.N ●
51.XH86.05.45.E ●

51.XH86.M5.90.M ●
51.XH86.M5.90.N ●
51.XH86.M5.90.E ●



I
A
D

51.XH86.05.30.* ●
51.XH86.05.30.S ●
51.XH86.05.30.B ●

51.XH86.05.45.* ●
51.XH86.05.45.S ●
51.XH86.05.45.B ●

51.XH86.M5.90.* ●
51.XH86.M5.90.S ●
51.XH86.M5.90.B ●

* 0 = dowels Ø10mm / D = dowels Ø8mm



I
A
D

51.XH88.05.30.V ●
51.XH88.05.30.U ●
51.XH88.05.30.Z ●

51.XH88.05.45.V ●
51.XH88.05.45.U ●
51.XH88.05.45.Z ●

51.XH88.M5.90.V ●
51.XH88.M5.90.U ●
51.XH88.M5.90.Z ●



I
A
D

51.XH89.05.30.0 ●
51.XH89.05.30.S ●
51.XH89.05.30.B ●

51.XH89.05.45.0 ●
51.XH89.05.45.S ●
51.XH89.05.45.B ●

51.XH89.M5.90.0 ●
51.XH89.M5.90.S ●
51.XH89.M5.90.B ●



I
A

51.XH8C.05.30.0
51.XH8C.05.30.0

51.XH8C.05.45.0
51.XH8C.05.45.0

51.XH8C.M5.90.0
51.XH8C.M5.90.0

● = G / Genios Solution

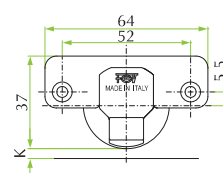
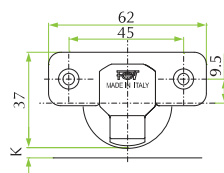
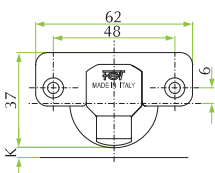

The mounting plates and fittings for this hinge series are shown from page 46 to page 59.

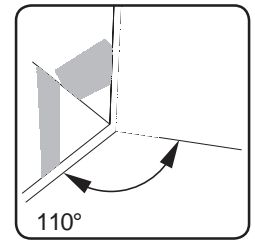
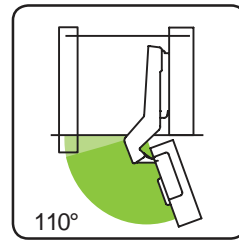

ANGLE 24°÷30°

ANGLE 45°

ANGLE 90°

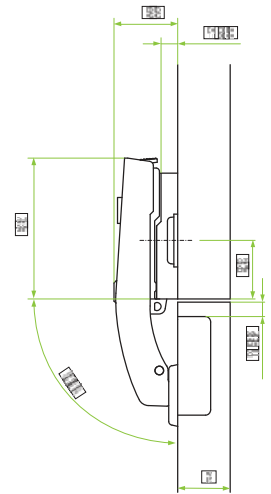
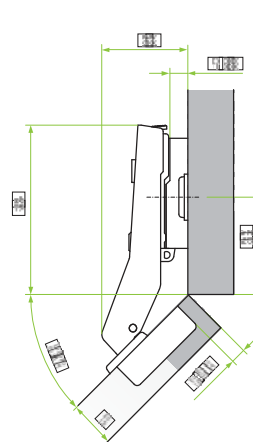
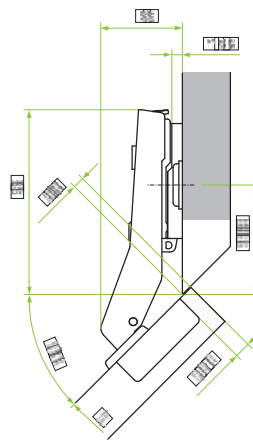
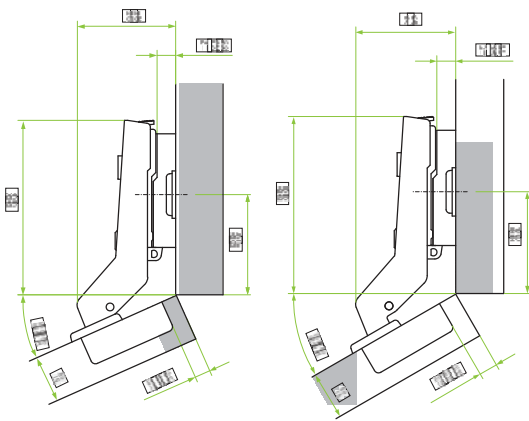

Table to determinate the minimum distance A so that a door with T thickness can open without protrusion from the cabinet and without interfering with adjacent doors.

T=	16	17	18	19	20	21	22	23	24	25	26
K=3 A=	0.55	0.75	1.10	1.45	1.80	2.40	3.10	3.90	4.70	6.70	6.50
K=4 A=	0.55	0.70	1.05	1.40	1.75	2.25	2.85	3.60	4.35	5.75	6.00
K=5 A=	0.53	0.70	1.00	1.35	1.65	2.10	2.65	3.30	4.00	4.75	5.55
K=6 A=	0.50	0.70	0.95	1.25	1.60	2.00	2.50	3.05	3.70	4.40	5.20
K=7 A=	0.50	0.65	0.85	1.20	1.55	1.90	2.35	2.85	3.45	4.10	4.80

Optim a Click for corner cabinet



Technical specifications:

- Depth of the metal cup 11.3mm
- Cup diameter 35mm
- Opening 110° with (K) max 4mm e (T) max 18mm
- Possibility of door drilling (K) from 3 to 7 mm
- Thickness of the door (T) from 16 to 26 mm



I
A
D

51.XH83.05.35.0

51.XH83.05.35.C

51.XH83.05.35.B

Available with premounted selftapping screws



I
A
D

51.XH84.05.35.M

51.XH84.05.35.N

51.XH84.05.35.E



I
A
D

51.XH84.05.35.*

51.XH84.05.35.S

51.XH84.05.35.B

* 0 = dowels Ø10mm / D = dowels Ø8mm



I
A
D

51.XH88.05.35.V

51.XH88.05.35.U

51.XH88.05.35.Z



I
A
D

51.XH89.05.35.0

51.XH89.05.35.S

51.XH89.05.35.B

I

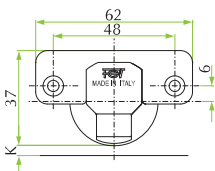

A

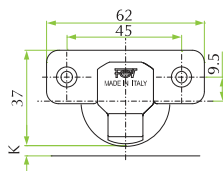

D

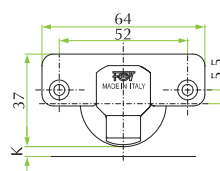

The mounting plates and fittings for this hinge series are shown from page 46 to page 59.

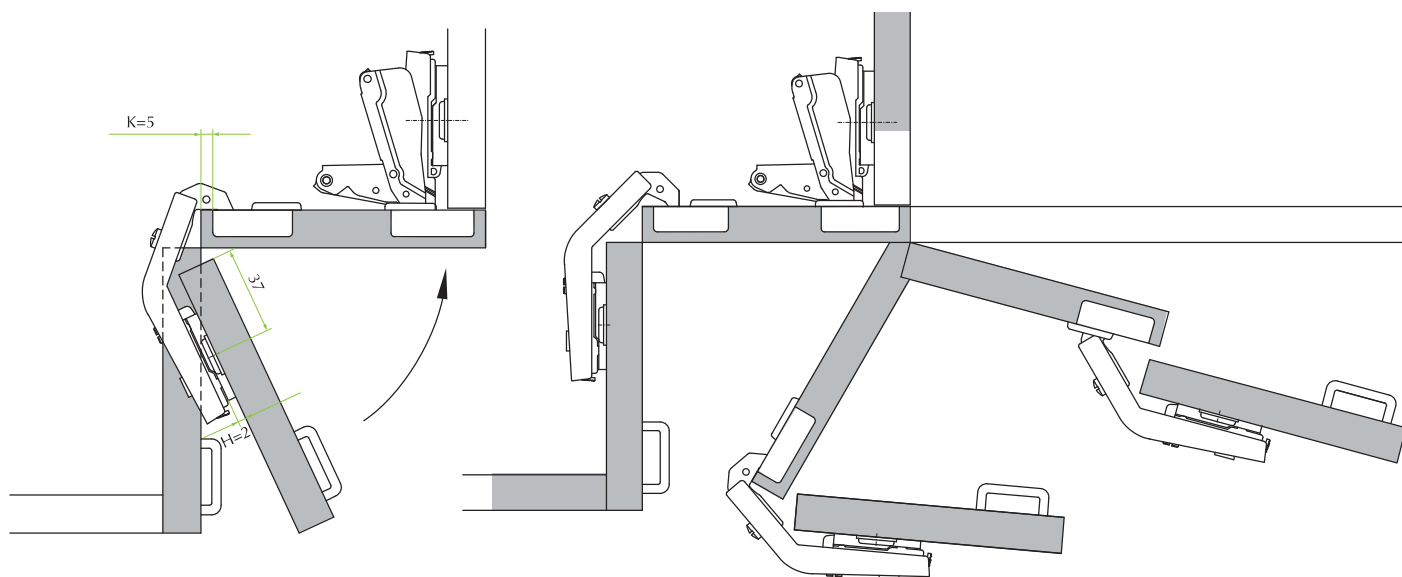
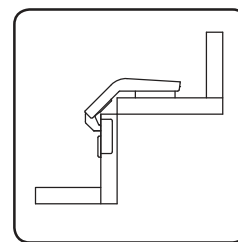

Optim a Click 105° for doors with aluminium frame



Technical specifications:

- Depth of the zamak cup 9.9mm
- Cup drilling 28x7mm
- Opening 105°
- Aluminium frame from min. 19 to max 25 mm
- OneTouch solutions

FIXING FOR GROOVED PROFILE

CRANK 0



51.XS91.05.00.0 ●

CRANK 8



51.XS91.05.08.0 ●

CRANK 15



51.XS91.05.15.0 ●

● = G / Genios Solution

Drilling holes:

The two laterals drillings are $\varnothing 4$ mm and are countersunk with 120°.
Screws $\varnothing 3.5 \times 12$ mm supplied on demand under code 1A05512105000.

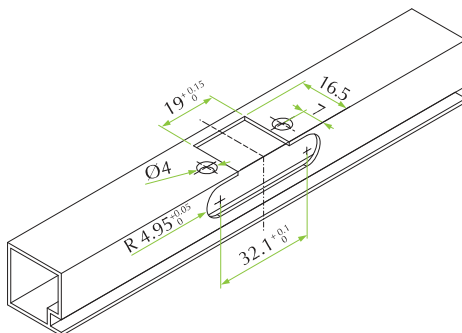

Assembly instructions:

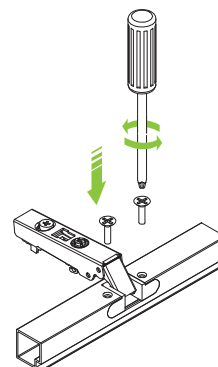
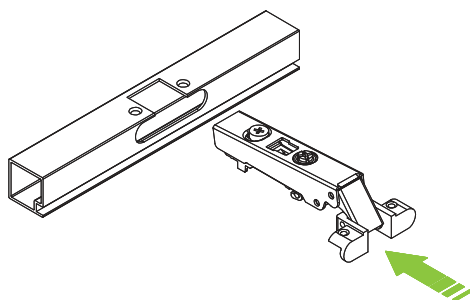

The mounting plates and fittings for this hinge series are shown from page 46 to page 59.

Optima Click 105° for doors with aluminium frame



Technical specifications:

- Depth of the zamak cup 9.9mm
- Opening 105°
- Aluminium frame from min. 19 to max 25 mm

LOCK FIXING

CRANK 0



51.XS81.05.00.0

CRANK 8



51.XS81.05.08.0

CRANK 15



51.XS81.05.15.0

Aluminium frame:

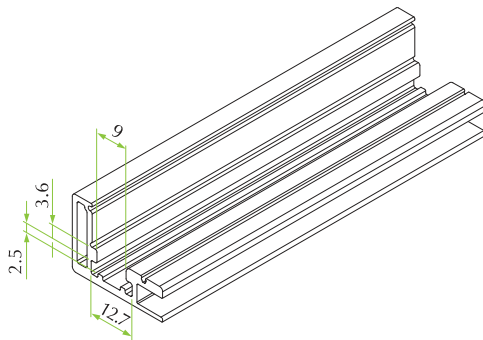

Assembly instructions:

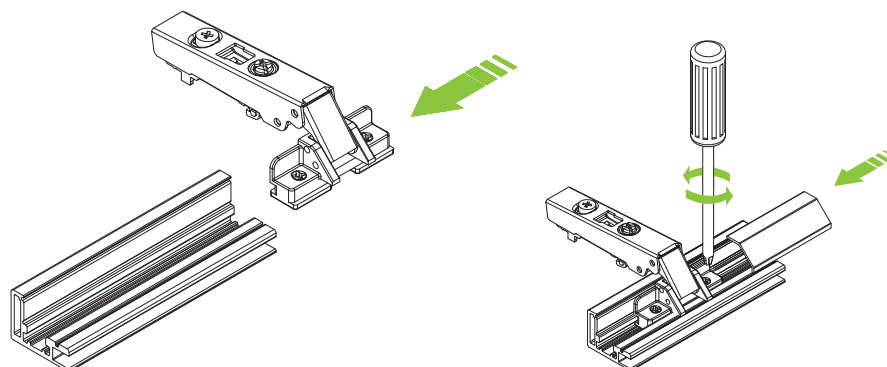

The mounting plates and fittings for this hinge series are shown from page 46 to page 59.

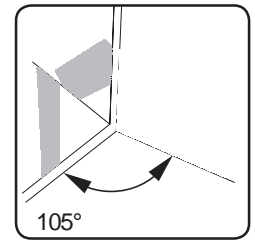
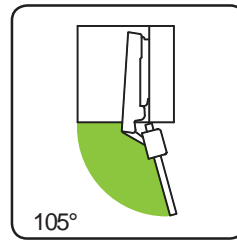

CRANK 0
For lay-on doors

CRANK 8
For partial lay-on doors

CRANK 15
For inset doors

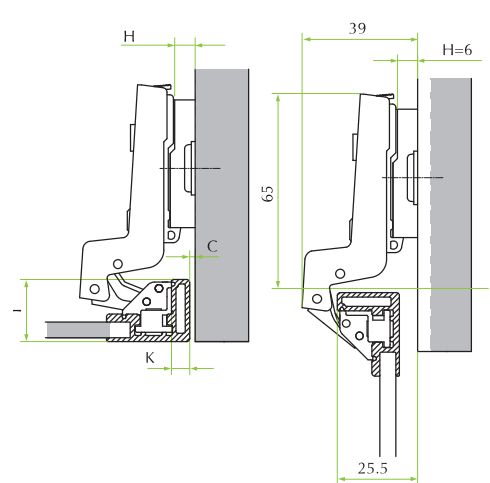
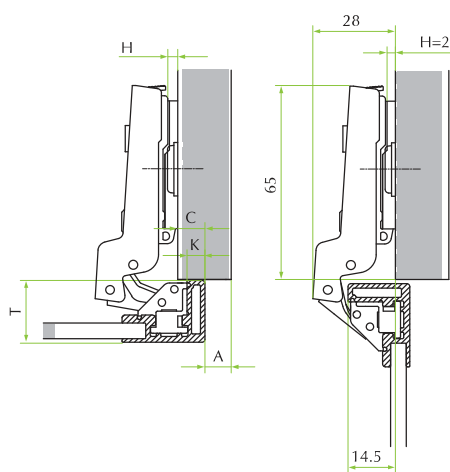
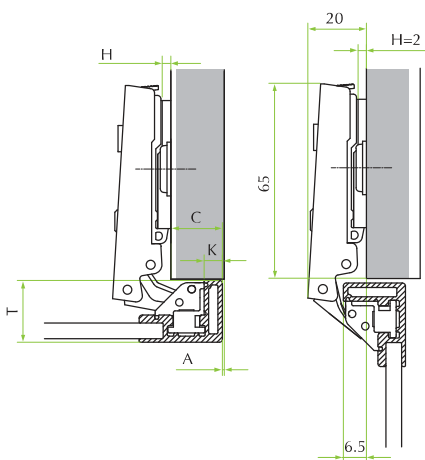

Overlay (C)	Drilling distance (K)						
	3	4	5	6	7		
19					2		
18				2			
17			2		4		
16		2		4			
15	2		4		6		
14		4		6			
13			4		6		
12				6			
11	6						Mounting plates (H)

Overlay (C)	Drilling distance (K)						
	3	4	5	6	7		
11					2		
10					2		
9			2		4		
8		2		4			
7	2		4		6		
6		4		6			
5			4		6		
4				6			
3	6						Mounting plates (H)

Overlay (C)	Drilling distance (K)						
	3	4	5	6	7		
0	2		4		6		
1		4		6			
2		4		6			
3			6				
4		6					
							Mounting plates (H)

Table to determinate the minimum distance A so that a door with T thickness can open without protrusion from the cabinet and without interfering with adjacent doors.

T=	16	17	18	19	20	21	22	23	24	25	26
K=3 A=	0.55	0.75	1.10	1.45	1.80	2.40	3.10	3.90	4.70	6.70	6.50
K=4 A=	0.55	0.70	1.05	1.40	1.75	2.25	2.85	3.60	4.35	5.75	6.00
K=5 A=	0.53	0.70	1.00	1.35	1.65	2.10	2.65	3.30	4.00	4.75	5.55
K=6 A=	0.50	0.70	0.95	1.25	1.60	2.00	2.50	3.05	3.70	4.40	5.20
K=7 A=	0.50	0.65	0.85	1.20	1.55	1.90	2.35	2.85	3.45	4.10	4.80

Optima Click 90° Ø40 for thick doors



Technical specifications:

- Depth of the metal cup 12.8mm
- Cup diameter 40mm
- Opening 90°
- Possibility of door drilling (K) from 3 to 15 mm
- Thickness of the door (T) from 16 to 40 mm
- OneTouch solutions

CRANK 0



CRANK 8



CRANKS 15, 22 TO PAGE 44 >>>

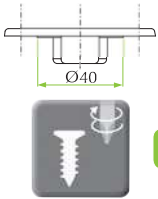

S

51.XH45.05.00.0

51.XH45.05.08.0

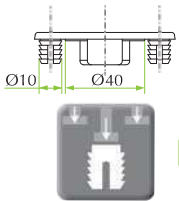

S

51.XH46.05.00.0

51.XH46.05.08.0

CRANK 0
For lay-on doors

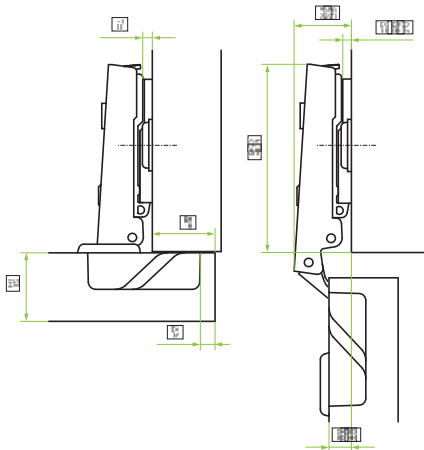

CRANK 8
For partial lay-on doors

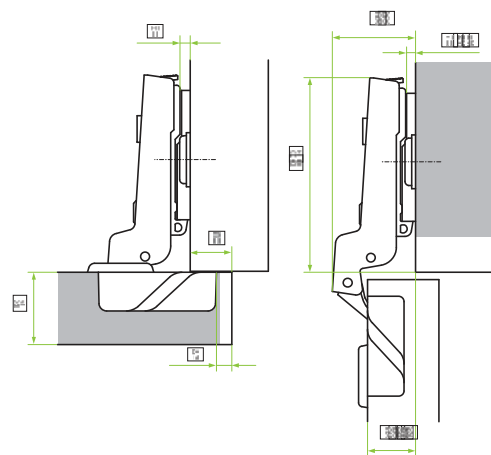

CUP HOLE DISTANCE 52x7.5mm

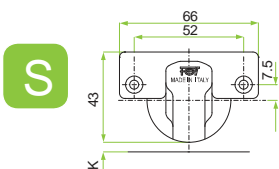

The mounting plates and fittings for this hinge series are shown from page 46 to page 59.

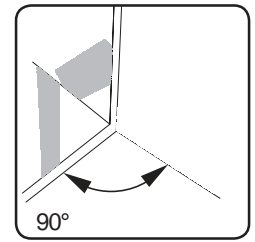
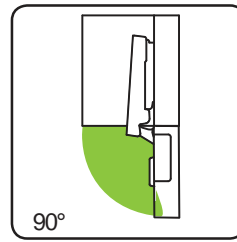

CRANK 0
For lay-on doors

		Drilling distance (K)													
		4	5	6	7	8	9	10	11	12	13	14	15		
Overlay (C)	32										0		2		
	31									0		2			
	30								0		2		4		
	29							0		2		4			
	28					0		2		4		6			
	27				0		2		4		6				
	26			0		2		4		6					
	25		0		2		4		6						
	24	0		2		4		6							
	23	0		2		4		6							
	22	2		4		6									
	21	2		4		6									
	20	4		6											
	19	4		6											
	18	6													
17	6														
		Mounting plates (H)													

CRANK 8
For partial lay-on doors

		Drilling distance (K)													
		4	5	6	7	8	9	10	11	12	13	14	15		
Overlay (C)	24										0		2		
	23									0		2			
	22								0		2		4		
	21							0		2		4			
	20					0		2		4		6			
	19				0		2		4		6				
	18			0		2		4		6					
	17		0		2		4		6						
	16	0		2		4		6							
	15	0		2		4		6							
	14	2		4		6									
	13	2		4		6									
	12	4		6											
	11	4		6											
	10	6													
9	6														
		Mounting plates (H)													

Table to determinate the minimum distance A so that a door with T thickness can open without protrusion from the cabinet and without interfering with adjacent doors.

T=	20	21	22	23	24	25	26	27	28	29	30	31	32	33	34	35	36	37	38	39	40
K=3 A=	0.20	0.35	0.55	0.70	0.90	1.05	1.25	1.40	1.60	2.25	3.20	4.15	5.05	6.05	7.00	8.00	9.00	9.95	10.95	11.95	12.95
K=4 A=	0.20	0.35	0.50	0.70	0.85	1.05	1.20	1.40	1.55	1.75	2.55	3.45	4.40	5.35	6.30	7.25	8.15	9.15	10.15	11.10	12.10
K=5 A=	0.15	0.35	0.50	0.70	0.85	1.05	1.20	1.40	1.55	1.70	2.05	2.80	3.75	4.70	5.65	6.55	7.50	8.45	9.40	10.35	11.25
K=6 A=	0.15	0.30	0.50	0.65	0.85	1.00	1.20	1.35	1.55	1.70	2.00	2.30	3.10	4.05	4.95	5.90	6.85	7.80	8.75	9.65	10.60
K=7 A=	0.15	0.30	0.50	0.65	0.85	1.00	1.15	1.35	1.50	1.70	1.90	2.25	2.60	3.50	4.35	5.25	6.20	7.15	8.05	9.00	9.95
K=8 A=	0.10	0.30	0.45	0.65	0.80	1.00	1.15	1.35	1.50	1.70	1.85	2.20	2.55	3.00	3.85	4.70	5.60	6.50	7.40	8.35	9.30
K=9 A=	0.10	0.25	0.45	0.60	0.80	0.95	1.15	1.30	1.50	1.65	1.85	2.15	2.50	2.80	3.35	4.20	5.10	5.95	6.80	7.70	8.65
K=10 A=	0.10	0.25	0.45	0.60	0.80	0.95	1.15	1.30	1.50	1.65	1.85	2.10	2.40	2.75	3.10	3.70	4.60	5.45	6.30	7.20	8.05
K=11 A=	0.05	0.25	0.40	0.60	0.75	0.95	1.10	1.30	1.45	1.60	1.80	2.00	2.35	2.70	3.05	3.40	4.10	4.95	5.80	6.70	7.55
K=12 A=	0.05	0.25	0.40	0.60	0.75	0.90	1.10	1.25	1.45	1.60	1.80	1.95	2.30	2.65	3.00	3.35	3.75	4.50	5.30	6.20	7.05
K=13 A=	0.05	0.20	0.40	0.55	0.75	0.90	1.10	1.25	1.45	1.60	1.80	1.95	2.25	2.60	2.90	3.25	3.60	4.15	4.90	5.70	6.55
K=14* A=	0.05	0.20	0.40	0.55	0.70	0.90	1.05	1.25	1.40	1.60	1.75	1.95	2.10	2.50	2.85	3.20	3.55	3.90	4.55	5.35	6.05
K=15* A=	0.00	0.20	0.35	0.55	0.70	0.90	1.05	1.25	1.40	1.55	1.75	1.90	2.10	2.45	2.80	3.15	3.50	3.85	4.25	4.95	5.75

* L= 0,77 • L= 1,76

Optima Click 90° Ø40 for thick doors



<<< CRANK 0, 8
TO PAGE 42

CRANK 15

CRANK 22

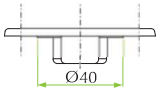

S

51.XH45.05.15.0

51.XH45.05.22.0

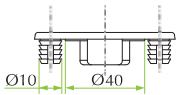

S

51.XH46.05.15.0

51.XH46.05.22.0

CRANK 15
For partial lay-on doors

CRANK 22
For inset doors

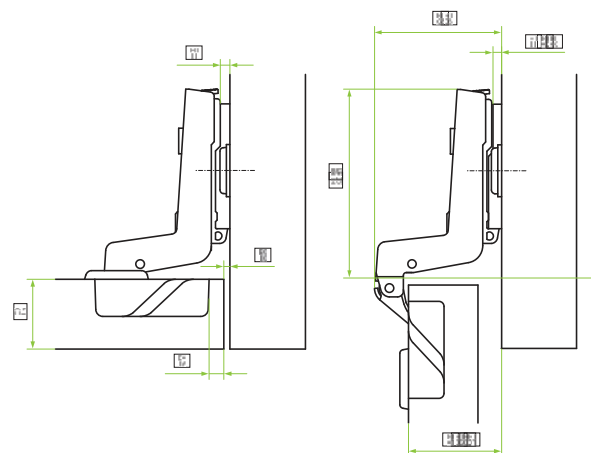
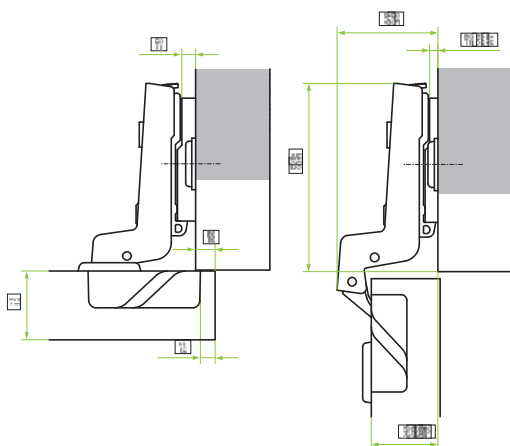

CUP HOLE DISTANCE 52x7.5mm

S

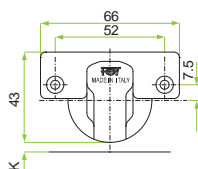

The mounting plates and fittings for this hinge series are shown from page 46 to page 59.

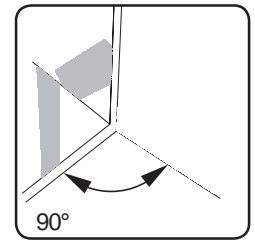
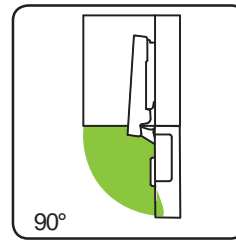

CRANK 15
For partial lay-on doors

		Drilling distance (K)													
		4	5	6	7	8	9	10	11	12	13	14	15		
Overlay (C)	17										0		2		
	16									0		2			
	15								0		2		4		
	14						0		2		4		4		
	13					0		2		4		4		6	
	12				0		2		4		6				
	11			0		2		4		6					
	10		0		2		4		6						
	9	0		2		4		6							
	8	0		2		4		6							
	7	2		4		6									
	6	2		4		6									
	5	4		6											
	4	4		6											
	3	6													
	2	6													

Mounting plates (H)

CRANK 22
For inset doors

		Drilling distance (K)											
		4	5	6	7	8	9	10	11	12			
Overlay (C)	0		2		4		6						
	1	2		4		6							
	2		4		6								
	3	4		6									
	4		6										
	5	6											
	6												
	7												

Mounting plates (H)

Table to determinate the minimum distance A so that a door with T thickness can open without protrusion from the cabinet and without interfering with adjacent doors.

T=	20	21	22	23	24	25	26	27	28	29	30	31	32	33	34	35	36	37	38	39	40
K=3 A=	0.20	0.35	0.55	0.70	0.90	1.05	1.25	1.40	1.60	2.25	3.20	4.15	5.05	6.05	7.00	8.00	9.00	9.95	10.95	11.95	12.95
K=4 A=	0.20	0.35	0.50	0.70	0.85	1.05	1.20	1.40	1.55	1.75	2.55	3.45	4.40	5.35	6.30	7.25	8.15	9.15	10.15	11.10	12.10
K=5 A=	0.15	0.35	0.50	0.70	0.85	1.05	1.20	1.40	1.55	1.70	2.05	2.80	3.75	4.70	5.65	6.55	7.50	8.45	9.40	10.35	11.25
K=6 A=	0.15	0.30	0.50	0.65	0.85	1.00	1.20	1.35	1.55	1.70	2.00	2.30	3.10	4.05	4.95	5.90	6.85	7.80	8.75	9.65	10.60
K=7 A=	0.15	0.30	0.50	0.65	0.85	1.00	1.15	1.35	1.50	1.70	1.90	2.25	2.60	3.50	4.35	5.25	6.20	7.15	8.05	9.00	9.95
K=8 A=	0.10	0.30	0.45	0.65	0.80	1.00	1.15	1.35	1.50	1.70	1.85	2.20	2.55	3.00	3.85	4.70	5.60	6.50	7.40	8.35	9.30
K=9 A=	0.10	0.25	0.45	0.60	0.80	0.95	1.15	1.30	1.50	1.65	1.85	2.15	2.50	2.80	3.35	4.20	5.10	5.95	6.80	7.70	8.65
K=10 A=	0.10	0.25	0.45	0.60	0.80	0.95	1.15	1.30	1.50	1.65	1.85	2.10	2.40	2.75	3.10	3.70	4.60	5.45	6.30	7.20	8.05
K=11 A=	0.05	0.25	0.40	0.60	0.75	0.95	1.10	1.30	1.45	1.60	1.80	2.00	2.35	2.70	3.05	3.40	4.10	4.95	5.80	6.70	7.55
K=12 A=	0.05	0.25	0.40	0.60	0.75	0.90	1.10	1.25	1.45	1.60	1.80	1.95	2.30	2.65	3.00	3.35	3.75	4.50	5.30	6.20	7.05
K=13 A=	0.05	0.20	0.40	0.55	0.75	0.90	1.10	1.25	1.45	1.60	1.80	1.95	2.25	2.60	2.90	3.25	3.60	4.15	4.90	5.70	6.55
K=14*A=	0.05	0.20	0.40	0.55	0.70	0.90	1.05	1.25	1.40	1.60	1.75	1.95	2.10	2.50	2.85	3.20	3.55	3.90	4.55	5.35	6.05
K=15*A=	0.00	0.20	0.35	0.55	0.70	0.90	1.05	1.25	1.40	1.55	1.75	1.90	2.10	2.45	2.80	3.15	3.50	3.85	4.25	4.95	5.75

* L= 0,77 • L= 1,76

Series Optim a Click

HOW TO CHOOSE YOUR MOUNTING PLATE

OPTIMA STANDARD MOUNTING PLATE

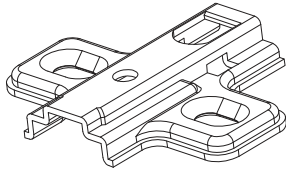

GENIOS R OPTIMA RETROFIT MOUNTING PLATE



OPTIMA GENIOS DAMPER

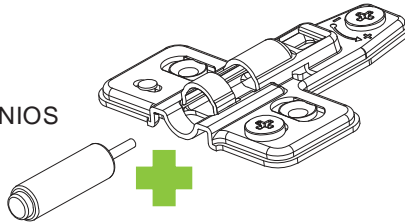

GENIOS G OPTIMA INTEGRATED MOUNTING PLATE

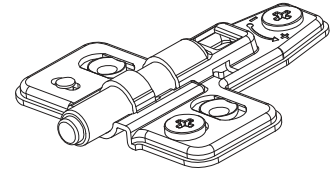

Genios Optima damper for Genios Optima Retrofit mounting plate.



Code

4H.0LAM.GU.X5.0CF

Metal cruciform mounting plate. Selftapping screw fixing. Vertical adjustment. Screws are provided on demand.

37

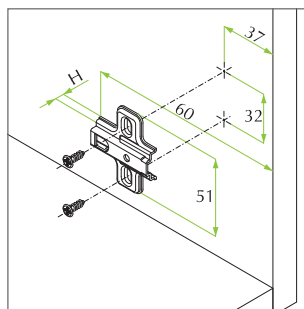

Height	Material	Code
H=2	Steel	52.0401.M5.02.0
H=4	Steel	52.0401.M5.04.0
H=6	Steel	52.0401.M5.06.0

Metal cruciform mounting plate. Selftapping screw fixing. Vertical adjustment. Screws are provided on demand.



37

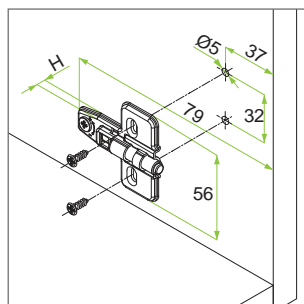

Height	Material	Code
H=2	Steel	52.0401.M5.02.0 ●
H=4	Steel	52.0401.M5.04.0 ●

● = G / Genios Integrated Solution
R / Genios Retrofit Solution

Metal cruciform mounting plate. Euro screws premounted. Vertical adjustment.

37

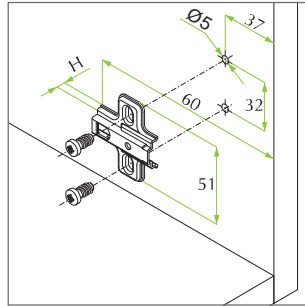

Height	Material	Code
H=2	Steel	52.0416.M5.02.*
H=4	Steel	52.0416.M5.04.*
H=6	Steel	52.0416.M5.06.*
H=10	Zama	52.0416.05.10.*

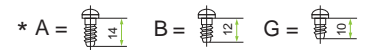

Metal cruciform mounting plate. Euro screws premounted. Vertical adjustment.

37

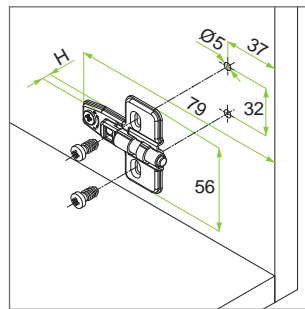

Height	Material	Code
H=2	Steel	52.0416.M5.02.* ●
H=4	Steel	52.0416.M5.04.* ●



Metal cruciform mounting plate. Premounted selftapping screws Ø4.7mm. Vertical adjustment.

37

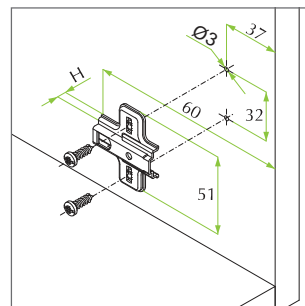

Height	Material	Code
H=2	Steel	52.04G5.M5.02.0
H=4	Steel	52.04G5.M5.04.0
H=6	Steel	52.04G5.M5.06.0

Metal cruciform mounting plate. Fixing by expanding X-Pando dowels Ø5mm. Vertical adjustment.

37

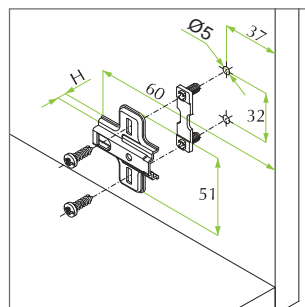

Height	Material	Code
H=2	Steel	52.04N5.M5.02.*
H=4	Steel	52.04N5.M5.04.*
H=6	Steel	52.04N5.M5.06.*



Series Optim a Click

Metal cruciform mounting plate. Fixing by expanding X-Pando dowels $\varnothing 5\text{mm}$. Vertical adjustment.

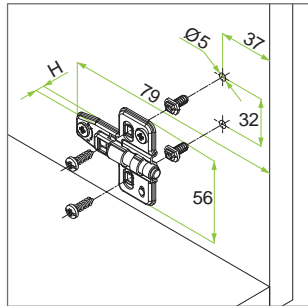

Height	Material	Code
H=2	Steel	52.04N5.M5.02.* ●
H=4	Steel	52.04N5.M5.04.* ●

* 0 = $\varnothing 5$

● = G / Genios Integrated Solution
R / Genios Retrofit Solution

Metal cruciform mounting plate. Knock-in fixing with dowels $\varnothing 8\text{mm}$. Vertical adjustment.

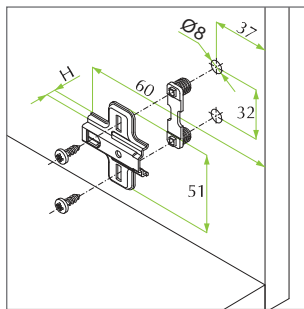

Height	Material	Code
H=2	Steel	52.04*5.M5.02.0
H=4	Steel	52.04*5.M5.04.0
H=6	Steel	52.04*5.M5.06.0

* C = $\varnothing 8$ E = 7.5

Metal cruciform mounting plate. Knock-in fixing with dowels $\varnothing 10\text{mm}$. Vertical adjustment.

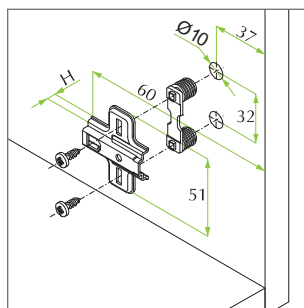

Height	Material	Code
H=2	Steel	52.04*5.M5.02.0
H=4	Steel	52.04*5.M5.04.0
H=6	Steel	52.04*5.M5.06.0

* D = $\varnothing 10$ F = 8.5

Asymmetric mounting plate for central panel. Fixing by dowels and premounted selftapping screws. Vertical adjustment.

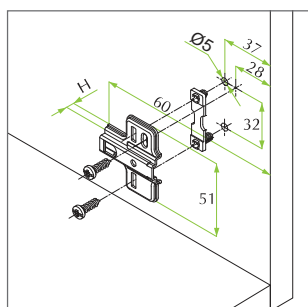

Height	Material	Code
H=2	Steel	52.54N7.M5.02.0
H=4	Steel	52.54N7.M5.04.0

Metal cruciform mounting plate. Selftapping screw fixing. Independent vertical adjustment with CAM. Screws are provided on demand.

37

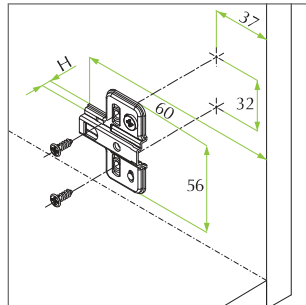

Height	Material	Code
H=2	Steel	52.R444.L5.02.0
H=4	Steel	52.R444.L5.04.0

Metal cruciform mounting plate. Selftapping screw fixing. Independent vertical adjustment with CAM. Screws are provided on demand.



37

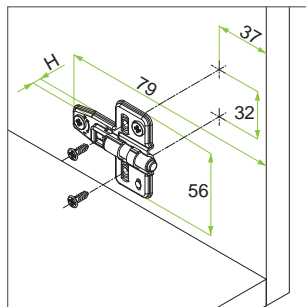

Height	Material	Code
H=2	Steel	52.R444.L5.02.0 ●
H=4	Steel	52.R444.L5.04.0 ●

● = G / Genios Integrated Solution
R / Genios Retrofit Solution

Metal cruciform mounting plate. Euro screws premounted. Independent vertical adjustment with CAM.

37

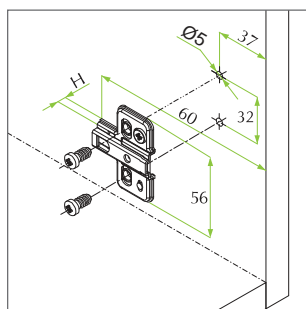

Height	Material	Code
H=2	Steel	52.R447.L5.02.*
H=4	Steel	52.R447.L5.04.*

* A = B = G =

Metal cruciform mounting plate. Euro screws premounted. Independent vertical adjustment with CAM.



37

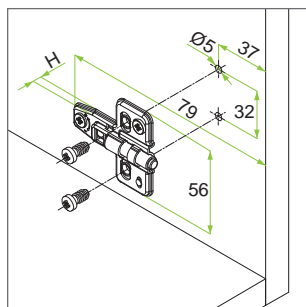

Height	Material	Code
H=2	Steel	52.R447.L5.02.* ●
H=4	Steel	52.R447.L5.04.* ●

* A = B = G = ● = G / Genios Integrated Solution
R / Genios Retrofit Solution

Series Optim a Click

Metal cruciform mounting plate. Fixing by expanding X-Pando dowels $\varnothing 5\text{mm}$. Independent vertical adjustment with CAM.

37

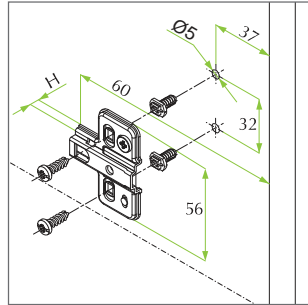

Height	Material	Code
H=2	Steel	52.R4N5.L5.02.*
H=4	Steel	52.R4N5.L5.04.*

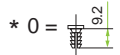

Metal cruciform mounting plate. Fixing by expanding X-Pando dowels $\varnothing 5\text{mm}$. Independent vertical adjustment with CAM.

37

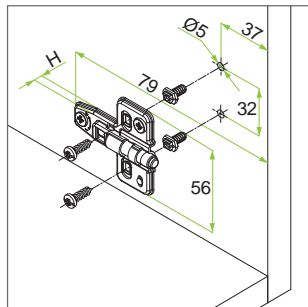

Height	Material	Code
H=2	Steel	52.R4N5.L5.02.*
H=4	Steel	52.R4N5.L5.04.*

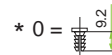

= G / Genios Integrated Solution
R / Genios Retrofit Solution

Metal cruciform mounting plate. Knock-in fixing with dowels $\varnothing 8\text{mm}$. Independent vertical adjustment with CAM.

37

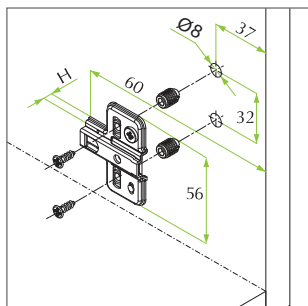

Height	Material	Code
H=2	Steel	52.R445.L5.02.0
H=4	Steel	52.R445.L5.04.0

Metal cruciform mounting plate. Knock-in fixing with dowels $\varnothing 8\text{mm}$. Independent vertical adjustment with CAM.

37

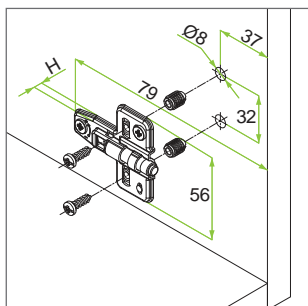

Height	Material	Code
H=2	Steel	52.R445.L5.02.0
H=4	Steel	52.R445.L5.04.0

= G / Genios Integrated Solution
R / Genios Retrofit Solution

Metal cruciform mounting plate. Knock-in fixing with dowels $\varnothing 10$ mm. Independent vertical adjustment with CAM.

37

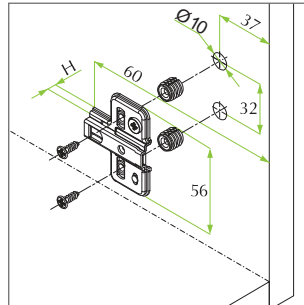

Height	Material	Code
H=2	Steel	52.R446.L5.02.0
H=4	Steel	52.R446.L5.04.0

Metal cruciform mounting plate. Knock-in fixing with dowels $\varnothing 10$ mm. Independent vertical adjustment with CAM.

37

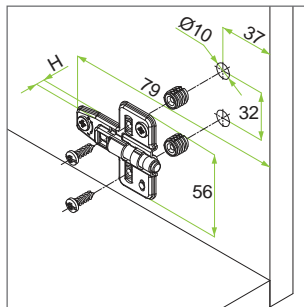

Height	Material	Code
H=2	Steel	52.R446.L5.02.0
H=4	Steel	52.R446.L5.04.0

= G / Genios Integrated Solution
R / Genios Retrofit Solution

Metal cruciform mounting plate. Selftapping screw fixing. Vertical adjustment. Screws are provided on demand.

28

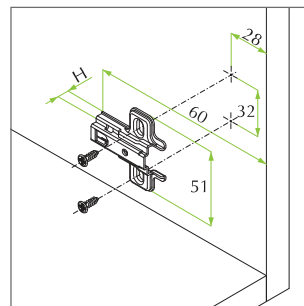

Height	Material	Code
H=4	Steel	52.0422.M5.04.0

Metal cruciform mounting plate. Selftapping screw fixing. Vertical adjustment. Screws are provided on demand.

28

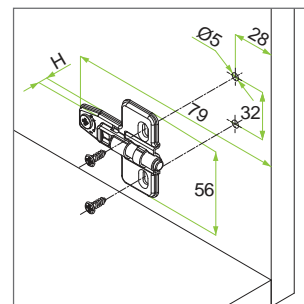

Height	Material	Code
H=2	Steel	52.0422.05.02.0
H=4	Steel	52.0422.05.04.0

= G / Genios Integrated Solution
R / Genios Retrofit Solution

Series Optim a Click

Metal cruciform mounting plate. Euro screws premounted. Vertical adjustment.

28

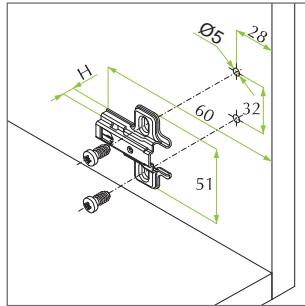

Height	Material	Code
H=4	Steel	52.0421.M5.04.*

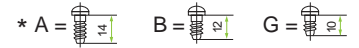

Metal cruciform mounting plate. Euro screws premounted. Vertical adjustment.

28

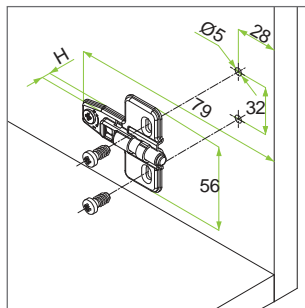

Height	Material	Code
H=2	Steel	52.0421.05.02.*
H=4	Steel	52.0421.05.04.*



Metal cruciform mounting plate. Fixing by expanding X-Pando dowels Ø5mm. Vertical adjustment.

28

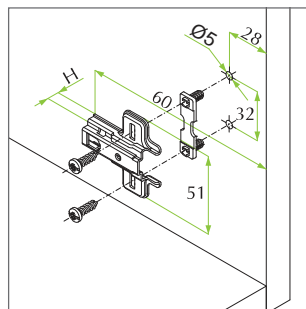

Height	Material	Code
H=4	Steel	52.04N1.M5.04.*



Metal cruciform mounting plate. Fixing by expanding X-Pando dowels Ø5mm. Vertical adjustment.

28

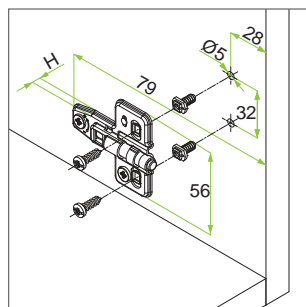

Height	Material	Code
H=2	Steel	52.04N1.05.02.*
H=4	Steel	52.04N1.05.04.*



Metal cruciform mounting plate. Knock-in fixing with dowels Ø8mm. Vertical adjustment. Not compatible with SlowMotion solutions.

28

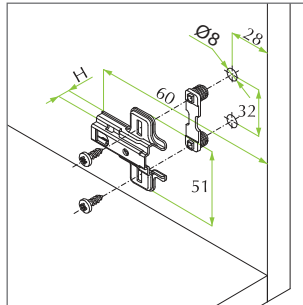

Height	Material	Code
H=4	Steel	52.04C1.M5.04.0

Metal cruciform mounting plate. Knock-in fixing with dowels Ø10mm. Vertical adjustment.

28

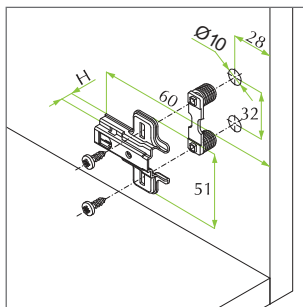

Height	Material	Code
H=4	Steel	52.04D1.M5.04.0

Asymmetric mounting plate for central panel. Fixing by dowels and premounted selftapping screws. Vertical adjustment.

28

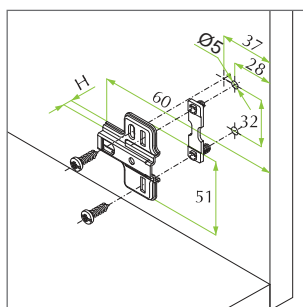

Height	Material	Code
H=2	Steel	52.54N3.M5.02.0
H=4	Steel	52.54N3.M5.04.0

Metal cruciform mounting plate. Selftapping screw fixing. Independent vertical adjustment with CAM. Screws are provided on demand.

28

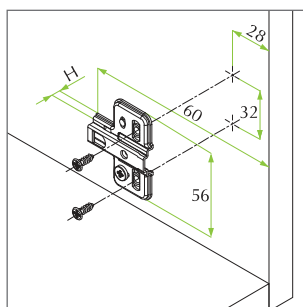

Height	Material	Code
H=2	Steel	52.R464.L5.02.0
H=4	Steel	52.R464.L5.04.0

Series Optim a Click

Metal cruciform mounting plate. Selftapping screw fixing. Independent vertical adjustment with CAM. Screws are provided on demand.

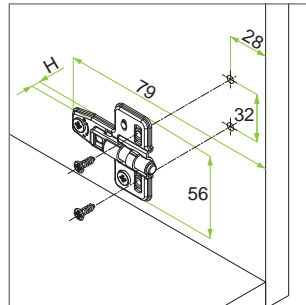

Height	Material	Code
H=2	Steel	52.R464.L5.02.0
H=4	Steel	52.R464.L5.04.0

= G / Genios Integrated Solution
R / Genios Retrofit Solution

Metal cruciform mounting plate. Euro screws premounted. Independent vertical adjustment with CAM.

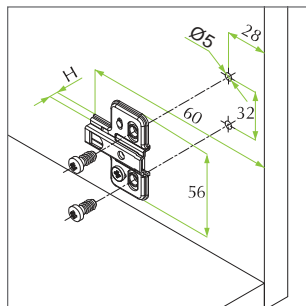

Height	Material	Code
H=2	Steel	52.R467.L5.02.*
H=4	Steel	52.R467.L5.04.*

* A = B = G =

Metal cruciform mounting plate. Euro screws premounted. Independent vertical adjustment with CAM.

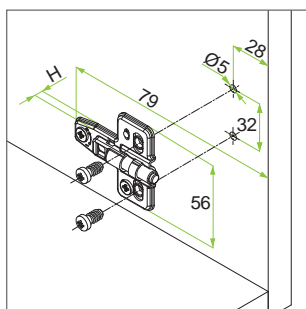

Height	Material	Code
H=2	Steel	52.R467.L5.02.*
H=4	Steel	52.R467.L5.04.*

* A = B = G = = G / Genios Integrated Solution
R / Genios Retrofit Solution

Metal cruciform mounting plate. Fixing by expanding X-Pando dowels Ø5mm. Independent vertical adjustment with CAM.

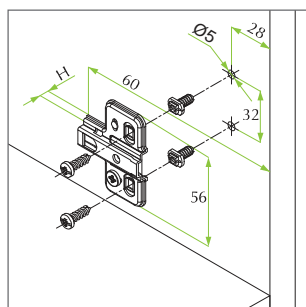

Height	Material	Code
H=2	Steel	52.R4N1.L5.02.*
H=4	Steel	52.R4N1.L5.04.*

* 0 =

Metal cruciform mounting plate. Fixing by expanding X-Pando dowels $\varnothing 5$ mm. Independent vertical adjustment with CAM.

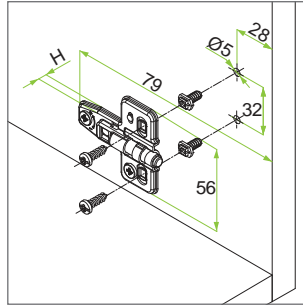

Height	Material	Code
H=2	Steel	52.R4N1.L5.02.*
H=4	Steel	52.R4N1.L5.04.*

* 0 = = G / Genios Integrated Solution
R / Genios Retrofit Solution

Metal cruciform mounting plate. Knock-in fixing with dowels $\varnothing 8$ mm. Independent vertical adjustment with CAM.

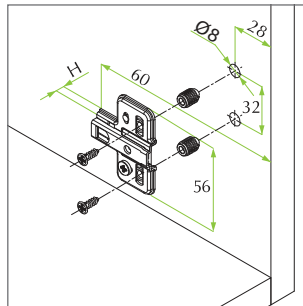

Height	Material	Code
H=2	Steel	52.R465.L5.02.0
H=4	Steel	52.R465.L5.04.0

Metal cruciform mounting plate. Knock-in fixing with dowels $\varnothing 8$ mm. Independent vertical adjustment with CAM.

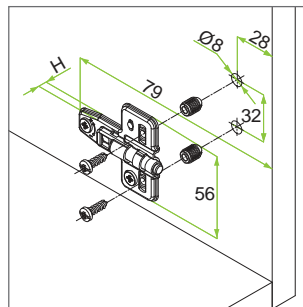

Height	Material	Code
H=2	Steel	52.R465.L5.02.0
H=4	Steel	52.R465.L5.04.0

= G / Genios Integrated Solution
R / Genios Retrofit Solution

Metal cruciform mounting plate. Knock-in fixing with dowels $\varnothing 10$ mm. Independent vertical adjustment with CAM.

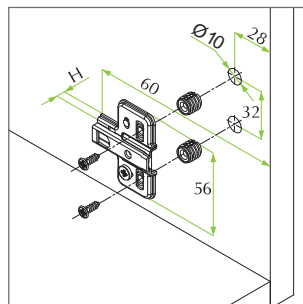

Height	Material	Code
H=2	Steel	52.R466.L5.02.0
H=4	Steel	52.R466.L5.04.0

Series Optim a Click

Metal cruciform mounting plate. Knock-in fixing with dowels $\varnothing 10\text{mm}$. Independent vertical adjustment with CAM.

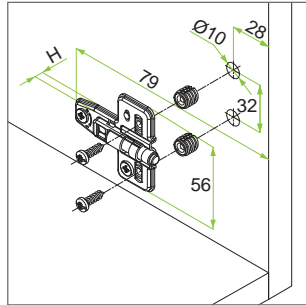

Height	Material	Code
H=2	Steel	52.R466.L5.02.0 ●
H=4	Steel	52.R466.L5.04.0 ●

● = G / Genios Integrated Solution
R / Genios Retrofit Solution

Zamak linear mounting plate. Selftapping screw fixing 3.5x15mm. Independent vertical adjustment with CAM. Screws are provided on demand (code 1A03050418000).

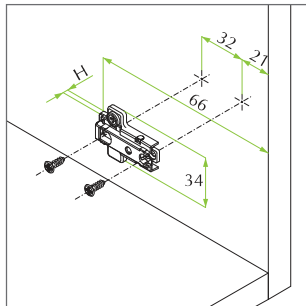

Height	Material	Code
H=3	Zamak	52.0448.R5.03.0
H=5	Zamak	52.0448.R5.05.0*

* Mounting plate provided on demand for minimum quantity ordered

Zamak linear mounting plate. Knock-in fixing with dowels $\varnothing 8\text{mm}$. Independent vertical adjustment with CAM.

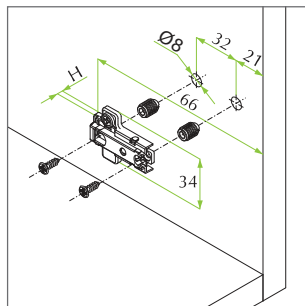

Height	Material	Code
H=3	Zamak	52.0449.R5.03.0
H=5	Zamak	52.0449.R5.05.0*

* Mounting plate provided on demand for minimum quantity ordered

Zamak linear mounting plate. Knock-in fixing with dowels $\varnothing 10\text{mm}$. Independent vertical adjustment with CAM.

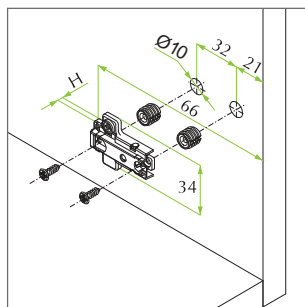

Height	Material	Code
H=3	Zamak	52.0450.R5.03.0
H=5	Zamak	52.0450.R5.05.0*

* Mounting plate provided on demand for minimum quantity ordered

Zamak linear mounting plate. Selftapping screw fixing 3.5x15mm. Vertical adjustment. Screws are provided on demand (code 1A03050418000).

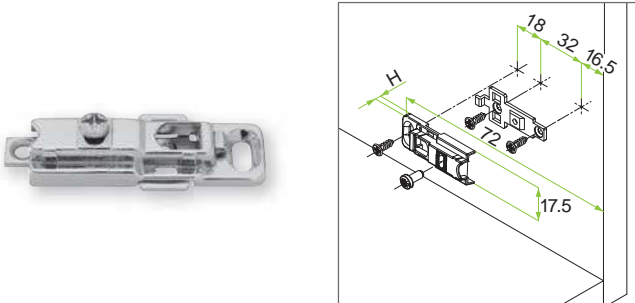

Height	Material	Code
H=2	Zamak	52.0408.05.02.000

Zamak linear mounting plate. Knock-in fixing with dowels Ø8mm. Vertical adjustment.

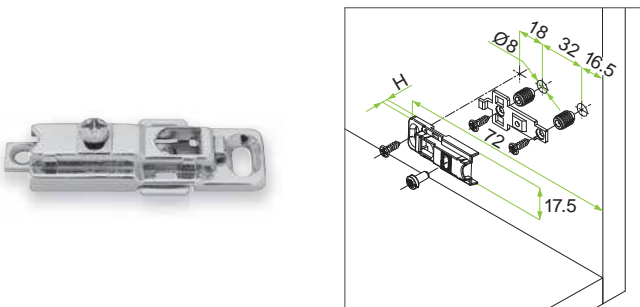

Height	Material	Code
H=2	Zamak	52.0409.05.02.000

Zamak linear mounting plate. Knock-in fixing with dowels Ø10mm. Vertical adjustment.

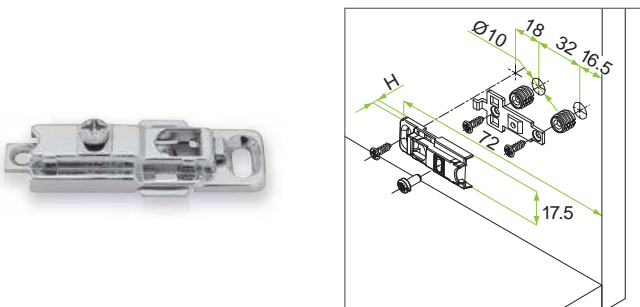

Height	Material	Code
H=2	Zamak	52.0410.05.02.000

Zamak mounting plate. Selftapping screw fixing. Vertical adjustment. Screws are provided on demand.

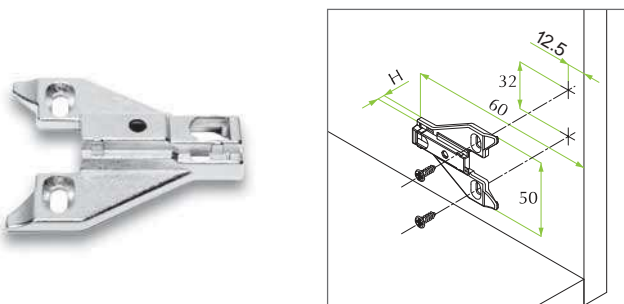

Height	Material	Code
H=2	Zamak	52.0432.05.02.0
H=5	Zamak	52.0432.05.05.0

Series Optim a Click

Spacer for mounting plates.

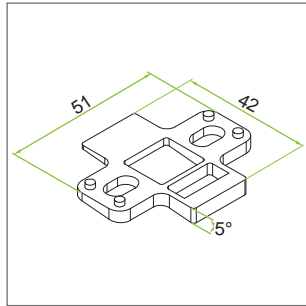

Material	Code
Nylon	52.0SP6.06.05.000

Stackable to get multiples of 5°.

Hinge arm cover.



Material	Code
Plastic	51.0M.00010.0000
Steel	51.0Y.00050.000N
Steel with FGV logo*	51.0YFGV.5.0000000

*Customer logo on demand.

Steel cover for hinge box.



Cup hole dist.	Material	Code
48-45	Steel	510C000500000
52	Steel	510C000500B00

Ø35mm cover.



Material	Code
Nylon	5307C3**00000

** Colour code: A1 = White RAL 9010 / A2 = Brown RAL 8016 / C6 = Grey RAL 7004 / 0I = Painted matt aluminium

Selftapping screws with Pozi drive head, nickel for hinge and mounting plate fixing.

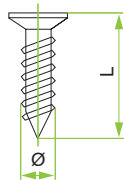

Ø	Length	Material	Code
4	12.5	Steel	1A035034150CF
4	15.5	Steel	1A035034250CF

Euro screws with Pozi drive head, nickel for mounting plate fixing.

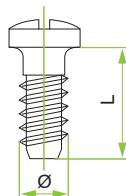

Ø	Length	Material	Code
6.3	10	Steel	1A075029350CF
6.3	12	Steel	1A075108250CF
6.3	14	Steel	1A075108150CF

Euro screws with Pozi drive head, nickel for hinge fixing.

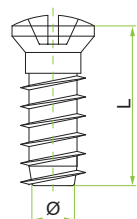

Ø	Length	Material	Code
6.3	12	Steel	1A075130050CF

Dowel in nylon for hinge fixing.

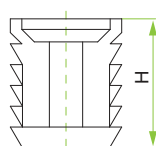

Ø	Height	Material	Code
10	12	Nylon	2H011070530CF
8	11	Nylon	2H000449003CF



MS Slide-On

The right function

Cost-effective Side-On mechanism

Wide range 3D door adjustment

Large program of cup-fixing methods

Genios Compatible

Option OneTouch

Complete range of solutions

The MSSide-On hinges represent the perfect synthesis between functional needs and right value of the product. The complete range allows to cover all the applications with a specific solution, adjustable to the needs of the user through easy and strong adjustments. The rapid (Velofix and X-Pando) or no-tool (Zip) door fixings allow assembly in a short time and in a safe way. The MSSide-On hinges are available in push-open version for use with the OneTouch device for handleless cabinet design. They are available in Genios configuration, and compatible with SlowMotion Alfa and SlowMotion Delta add-on damper solutions as well.

MS Slide-On

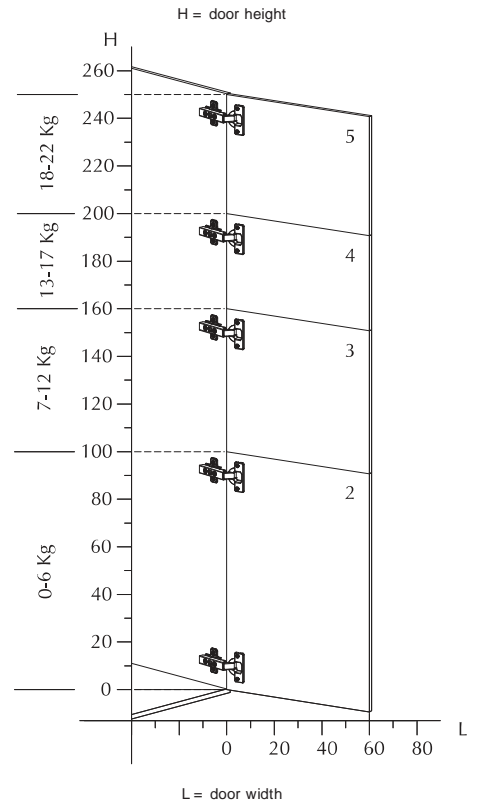

Mounting System



1 Place the rear part of the hinge on the front side of the mounting plate.



2 Let the hinge side on the mounting plate until it stops.



3 Tighten the connecting screw.

Adjusting System

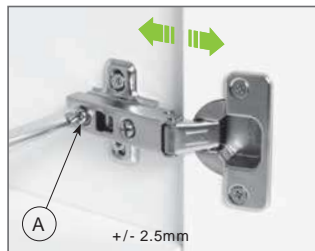

Front adjustment
Acting on the "A" screw it is possible to adjust the distance between the side of the cabinet and the door.

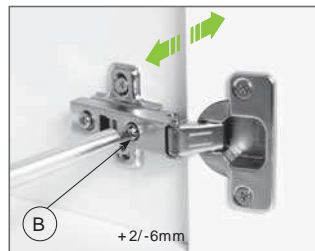



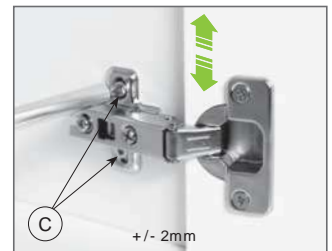







Independent side adjustment
Acting on the "B" screw it is possible to change the amount of the door covering on the side of the cabinet.



Vertical adjustment
Acting on the "C" screw of the mounting plate it is possible to adjust the door vertically.

INDEX

OPENING 110°		Summary table	p. 64
		Product detail	p. 68
OPENING 125°		Summary table	p. 64
		Product detail	p. 72
OPENING 125°		Summary table	p. 64
		Product detail	p. 74
FOR THICK DOORS 95° Ø35		Summary table	p. 64
		Product detail	p. 76
FOR CORNER DOORS 110°		Summary table	p. 64
		Product detail	p. 80
FOR CORNER CABINET		Summary table	p. 64
		Product detail	p. 84
SPECIAL SOLUTIONS			
FOR THICK DOORS 90° Ø40		Summary table	p. 67
		Product detail	p. 86
FOR WOOD AND/OR GLASS DOORS 90° Ø26		Summary table	p. 67
		Product detail	p. 90
FOR DOORS WITH ALUMINIUM FRAME 105°		Summary table	p. 67
		Product detail	p. 94
FLAP DOORS		Summary table	p. 67
		Product detail	p. 98
ZIP FIXING SYSTEM		Summary table	p. 67

Cup hole distance 48x6mm

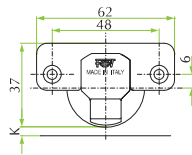

OPENING 110°



Crank 0		p. 68	p. 68	p. 68	p. 68	p. 68
Crank 4		p. 68	p. 68	p. 68	p. 68	p. 68
Crank 8		p. 70	p. 70	p. 70	p. 70	p. 70
Crank 15		p. 70	p. 70	p. 70	p. 70	p. 70

OPENING 125°



Crank 0		p. 72	p. 72	p. 72	p. 72	p. 72
Crank 8		p. 72	p. 72	p. 72	p. 72	p. 72

OPENING 175°



Crank 0		p. 74	p. 74	p. 74	p. 74	p. 74
Crank 8		p. 74	p. 74	p. 74	p. 74	p. 74

FOR THICK DOORS STANDARD OPENING 95° Ø35



Crank 0		p. 76	p. 76	p. 76	p. 76	p. 76
Crank 4		p. 76	p. 76	p. 76	p. 76	p. 76
Crank 8		p. 78	p. 78	p. 78	p. 78	p. 78
Crank 15		p. 78	p. 78	p. 78	p. 78	p. 78

FOR CORNER DOORS 110°

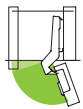

Angle -25°		p. 80	p. 80	p. 80	p. 80	p. 80
Angle +25°		p. 80	p. 80	p. 80	p. 80	p. 80
Angle 24°±30°		p. 82	p. 82	p. 82	p. 82	p. 82
Angle 45°		p. 82	p. 82	p. 82	p. 82	p. 82
Angle 90°		p. 82	p. 82	p. 82	p. 82	p. 82

FOR CORNER CABINET



p. 84	p. 84	p. 84	p. 84
-------	-------	-------	-------



SELF TAPPING
SCREW

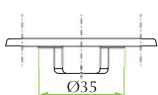

EURO
SCREW

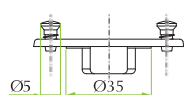

DOWEL

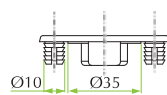

VELOFIX
DOWEL

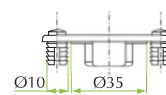

X-PANDO
DOWEL

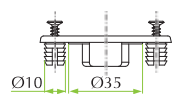

Cup hole distance
45x9.5mm

A

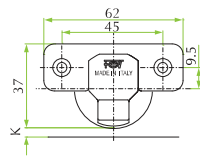

OPENING 110°



Crank 0		p. 68	p. 68	p. 68	p. 68	p. 68
Crank 4		p. 68	p. 68	p. 68	p. 68	p. 68
Crank 8		p. 70	p. 70	p. 70	p. 70	p. 70
Crank 15		p. 70	p. 70	p. 70	p. 70	p. 70

OPENING 125°



Crank 0		p. 72	p. 72	p. 72	p. 72	
Crank 8		p. 72	p. 72	p. 72	p. 72	

OPENING 175°



Crank 0		p. 74	p. 74	p. 74	p. 74	
Crank 8		p. 74	p. 74	p. 74	p. 74	

FOR THICK DOORS
STANDARD OPENING 95° Ø35



Crank 0		p. 76	p. 76	p. 76	p. 76	
Crank 4		p. 76	p. 76	p. 76	p. 76	
Crank 8		p. 78	p. 78	p. 78	p. 78	
Crank 15		p. 78	p. 78	p. 78	p. 78	

FOR CORNER DOORS 110°



Angle -25°		p. 80	p. 80	p. 80	p. 80	
Angle +25°		p. 80	p. 80	p. 80	p. 80	
Angle 24°±30°		p. 82	p. 82	p. 82	p. 82	p. 82
Angle 45°		p. 82	p. 82	p. 82	p. 82	p. 82
Angle 90°		p. 82	p. 82	p. 82	p. 82	p. 82

FOR CORNER
CABINET



	p. 84	p. 84	p. 84	p. 84
--	-------	-------	-------	-------



SELFTAPPING
SCREW

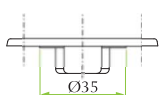

EURO
SCREW

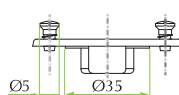

DOWEL

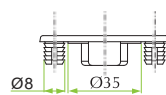

VELOFIX
DOWEL

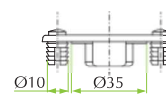

X-PANDO
DOWEL

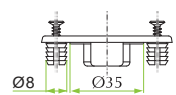

Cup hole distance
52x5.5mm

D

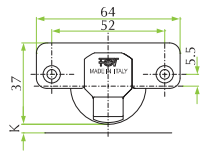

OPENING 110°



Crank 0		p. 68	p. 68	p. 68	p. 68	p. 68
Crank 4		p. 68	p. 68	p. 68	p. 68	p. 68
Crank 8		p. 70	p. 70	p. 70	p. 70	p. 70
Crank 15		p. 70	p. 70	p. 70	p. 70	p. 70

OPENING 125°



Crank 0		p. 72	p. 72	p. 72	p. 72	
Crank 8		p. 72	p. 72	p. 72	p. 72	

OPENING 175°



Crank 0		p. 74	p. 74	p. 74	p. 74	
Crank 8		p. 74	p. 74	p. 74	p. 74	

FOR THICK DOORS
STANDARD OPENING 95° Ø35



Crank 0		p. 76	p. 76	p. 76	p. 76	
Crank 4		p. 76	p. 76	p. 76	p. 76	
Crank 8		p. 78	p. 78	p. 78	p. 78	
Crank 15		p. 78	p. 78	p. 78	p. 78	

FOR CORNER DOORS 110°



Angle -25°		p. 80	p. 80	p. 80	p. 80	
Angle +25°		p. 80	p. 80	p. 80	p. 80	
Angle 24°±30°		p. 82	p. 82	p. 82	p. 82	p. 82
Angle 45°		p. 82	p. 82	p. 82	p. 82	p. 82
Angle 90°		p. 82	p. 82	p. 82	p. 82	p. 82

FOR CORNER
CABINET



p. 84	p. 84	p. 84	p. 84
-------	-------	-------	-------



SELF-TAPPING
SCREW

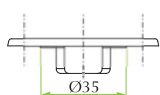

EURO
SCREW

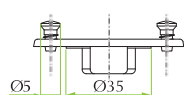

DOWEL

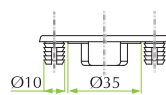

VELOFIX
DOWEL

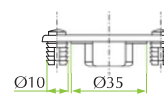

X-PANDO
DOWEL

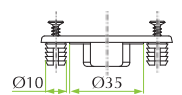

SPECIAL SOLUTIONS

CUP HOLE DISTANCE 52x7.5mm

S

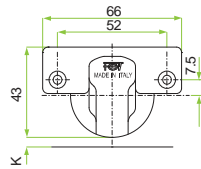

SELFTAPPING SCREW

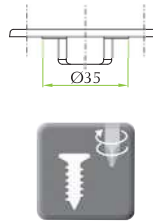

DOWEL

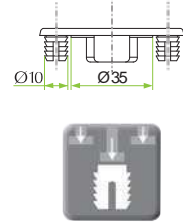

FOR THICK DOORS
OPENING 90° Ø40



Crank 0	
Crank 8	
Crank 15	
Crank 22	

p. 86

p. 86

p. 86

p. 86

p. 88

p. 88

p. 88

p. 88

CUP HOLE DISTANCE 38x8mm

M

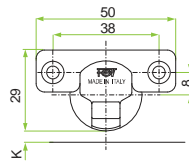

SELFTAPPING SCREW



EURO SCREW

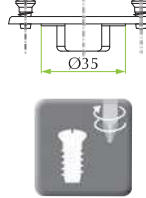

DOWEL

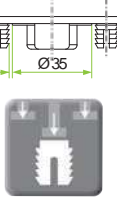

NYLON (glass)

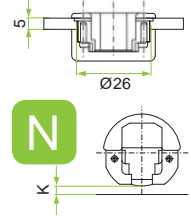

FOR WOOD AND/OR GLASS
DOORS 90° Ø26



Crank 0	
Crank 8	
Crank 15	

p. 90

p. 90

p. 90

p. 92

p. 90

p. 90

p. 90

p. 92

p. 90

p. 90

p. 90

p. 92

GROOVED PROFILE

LOCK FIXING

FOR DOORS WITH ALUMINIUM FRAME
OPENING 105°



Crank 0	
Crank 8	
Crank 15	

p. 94

p. 96

p. 94

p. 96

p. 94

p. 96

FOR FLAP DOORS

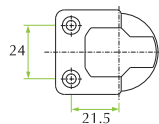

LEFT

RIGHT

p. 98

p. 98

ZIP FIXING SYSTEM

The Zip dowels allow a no-tool mounting of the hinge.

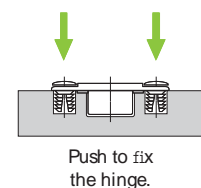
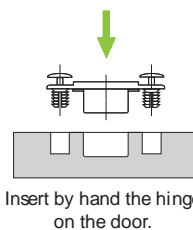

The hinges with Zip fixing system are available on demand. Please contact the FGV Customer Service.