

MS Slide-On 110°



Technical specifications:

- Depth of the metal cup 11.3mm
- Cup diameter 35mm
- Opening 110° with (K) max 4mm e (T) max 18mm
- Possibility of door drilling (K) from 3 to 7 mm
- Thickness of the door (T) from 16 to 26 mm
- Genios, SlowMotion Alfa and OneTouch solutions

CRANK 0



CRANK 4



CRANKS 8, 15 TO PAGE 70 >>>



I
A
D

51.MS15.05.00.0 ●

51.MS15.05.00.C ●

51.MS15.05.00.B ●

Available with premounted selftapping screws

51.MS15.05.04.0 ●

51.MS15.05.04.C ●

51.MS15.05.04.B ●



I
A
D

51.MS16.05.00.M ●

51.MS16.05.00.N ●

51.MS16.05.00.E ●

51.MS16.05.04.M ●

51.MS16.05.04.N ●

51.MS16.05.04.E ●



I
A
D

51.MS16.05.00.* ●

51.MS16.05.00.S ●

51.MS16.05.00.B ●

* 0 = dowels Ø10mm / D = dowels Ø8mm

51.MS16.05.04.* ●

51.MS16.05.04.S ●

51.MS16.05.04.B ●



I
A
D

51.MS18.05.00.V ●

51.MS18.05.00.U ●

51.MS18.05.00.Z ●

51.MS18.05.04.V ●

51.MS18.05.04.U ●

51.MS18.05.04.Z ●



I
A
D

51.MS19.05.00.0 ●

51.MS19.05.00.S ●

51.MS19.05.00.B ●

51.MS19.05.04.0 ●

51.MS19.05.04.S ●

51.MS19.05.04.B ●

● = G / Genios Solution

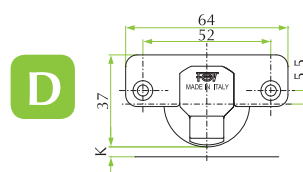
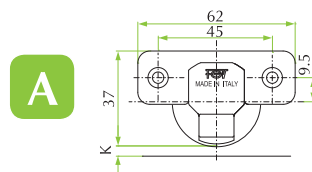
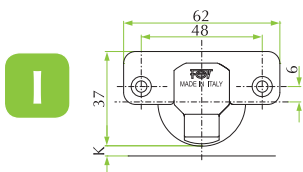

The mounting plates and fittings for this hinge series are shown from page 100 to page 107.

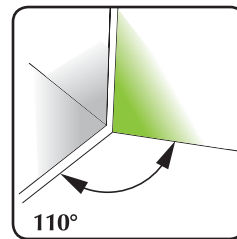
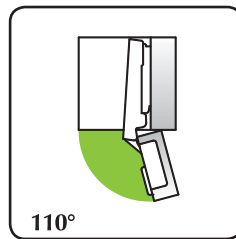
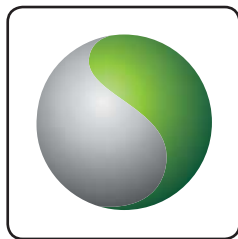

CRANK 0
For lay-on doors

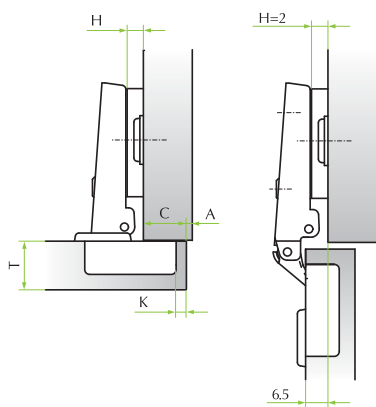

CRANK 4
For partial lay-on doors

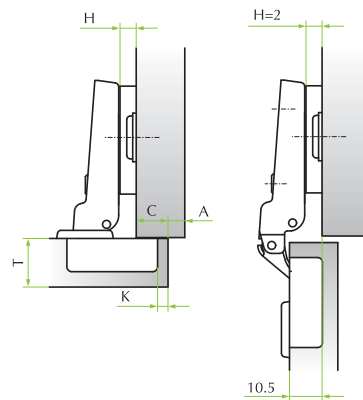

		Drilling distance (K)						
		3	4	5	6	7		
Overlay (C)	19			0		2		
	18		0		2			
	17	0		2		4		
	16		2		4			
	15	2		4		6		
	14		4		6			
	13	4		6				
	12		6					
11	6						Mounting plates (H)	

		Drilling distance (K)						
		3	4	5	6	7		
Overlay (C)	15			0		2		
	14		0		2			
	13	0		2		4		
	12		2		4			
	11	2		4		6		
	10		4		6			
	9	4		6				
	8		6					
7	6						Mounting plates (H)	

Table to determinate the minimum distance **A** so that a door with **T** thickness can open without protrusion from the cabinet and without interfering with adjacent doors.

T=		16	17	18	19	20	21	22	23	24	25	26
K=3	A=	0.55	0.75	1.10	1.45	1.80	2.40	3.10	3.90	4.70	6.70	6.50
K=4	A=	0.55	0.70	1.05	1.40	1.75	2.25	2.85	3.60	4.35	5.75	6.00
K=5	A=	0.55	0.70	1.00	1.35	1.65	2.10	2.65	3.30	4.00	4.75	5.55
K=6	A=	0.50	0.70	0.95	1.25	1.60	2.00	2.50	3.05	3.70	4.40	5.20
K=7	A=	0.50	0.65	0.85	1.20	1.55	1.90	2.35	2.85	3.45	4.10	4.80

MS Slide-On 110°



<<< CRANK 0, 4 TO PAGE 68

CRANK 8

CRANK 15



I
A
D

51.MS15.05.08.0 ●
51.MS15.05.08.C ●
51.MS15.05.08.B ●

51.MS15.05.15.0 ●
51.MS15.05.15.C ●
51.MS15.05.15.B ●

Available with premounted selftapping screws



I
A
D

51.MS16.05.08.M ●
51.MS16.05.08.N ●
51.MS16.05.08.E ●

51.MS16.05.15.M ●
51.MS16.05.15.N ●
51.MS16.05.15.E ●



I
A
D

51.MS16.05.08.* ●
51.MS16.05.08.S ●
51.MS16.05.08.B ●

51.MS16.05.15.* ●
51.MS16.05.15.S ●
51.MS16.05.15.B ●

* 0 = dowels Ø10mm / D = dowels Ø8mm



I
A
D

51.MS18.05.08.V ●
51.MS18.05.08.U ●
51.MS18.05.08.Z ●

51.MS18.05.15.V ●
51.MS18.05.15.U ●
51.MS18.05.15.Z ●



I
A
D

51.MS19.05.08.0 ●
51.MS19.05.08.S ●
51.MS19.05.08.B ●

51.MS19.05.15.0 ●
51.MS19.05.15.S ●
51.MS19.05.15.B ●

● = G / Genios Solution

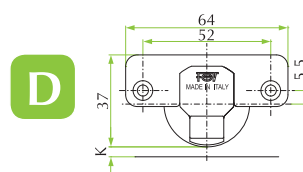
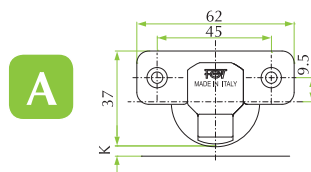
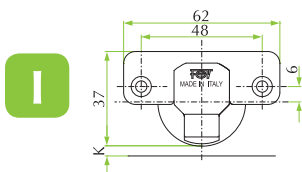

The mounting plates and fittings for this hinge series are shown from page 100 to page 107.

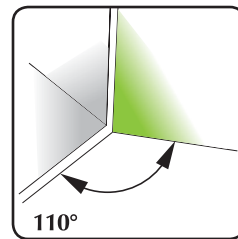
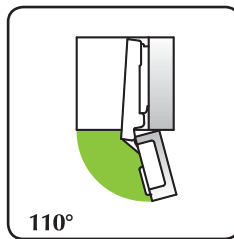

CRANK 8
For partial lay-on doors

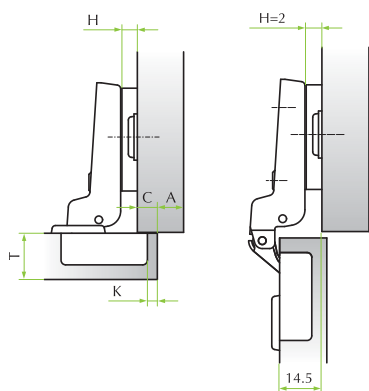

CRANK 15
For inset doors

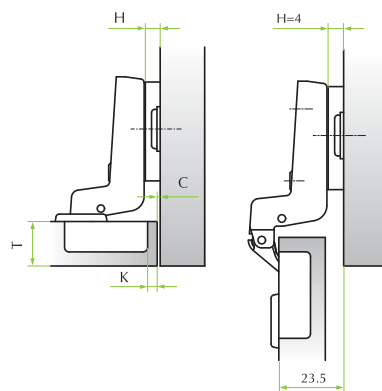

		Drilling distance (K)						
		3	4	5	6	7		
Overlay (C)	11			0		2		
	10		0		2			
	9	0		2		4		
	8		2		4			
	7	2		4		6		
	6		4		6			
	5	4		6				
	4		6					
3	6							
		Mounting plates (H)						

		Drilling distance (K)						
		3	4	5	6	7		
Overlay (C)	0	2		4		6		
	1		4		6			
	2	4		6				
	3		6					
	4	6						
		Mounting plates (H)						

Table to determinate the minimum distance **A** so that a door with **T** thickness can open without protrusion from the cabinet and without interfering with adjacent doors.

T=	A=	16	17	18	19	20	21	22	23	24	25	26
K=3	A=	0.55	0.75	1.10	1.45	1.80	2.40	3.10	3.90	4.70	6.70	6.50
K=4	A=	0.55	0.70	1.05	1.40	1.75	2.25	2.85	3.60	4.35	5.75	6.00
K=5	A=	0.55	0.70	1.00	1.35	1.65	2.10	2.65	3.30	4.00	4.75	5.55
K=6	A=	0.50	0.70	0.95	1.25	1.60	2.00	2.50	3.05	3.70	4.40	5.20
K=7	A=	0.50	0.65	0.85	1.20	1.55	1.90	2.35	2.85	3.45	4.10	4.80

MS Slide-On 125°



Technical specifications:

- Depth of the metal cup 12.3mm
- Cup diameter 35mm
- Opening 125° with (K) max 4mm e (T) max 18mm
- Possibility of door drilling (K) from 3 to 5 mm
- Thickness of the door (T) from 16 to 26 mm

CRANK 0



CRANK 8



I
A
D

51.MK15.M5.00.0

51.MK15.M5.00.C

51.MK15.M5.00.B

Available with premounted selftapping screws

51.MK15.M5.08.0

51.MK15.M5.08.C

51.MK15.M5.08.B



I
A
D

51.MK16.M5.00.M

51.MK16.M5.00.N

51.MK16.M5.00.E

51.MK16.M5.08.M

51.MK16.M5.08.N

51.MK16.M5.08.E



I
A
D

51.MK16.M5.00.*

51.MK16.M5.00.S

51.MK16.M5.00.B

* 0 = dowels Ø10mm / D = dowels Ø8mm

51.MK16.M5.08.*

51.MK16.M5.08.S

51.MK16.M5.08.B



I
A
D

51.MK18.M5.00.V

51.MK18.M5.00.U

51.MK18.M5.00.Z

51.MK18.M5.08.V

51.MK18.M5.08.U

51.MK18.M5.08.Z

I

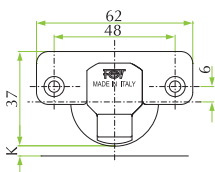

A

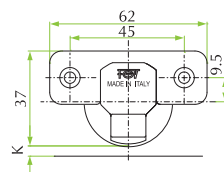

D

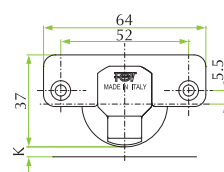

The mounting plates and fittings for this hinge series are shown from page 100 to page 107.

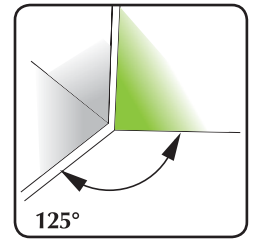
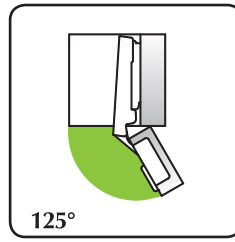

CRANK 0
For lay-on doors

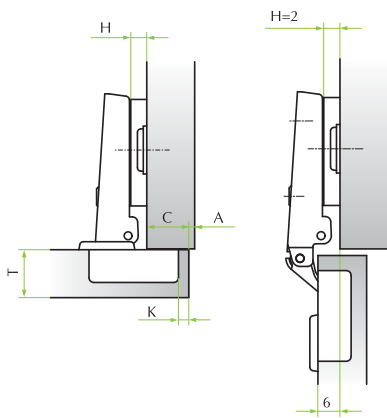

CRANK 8
For partial lay-on doors

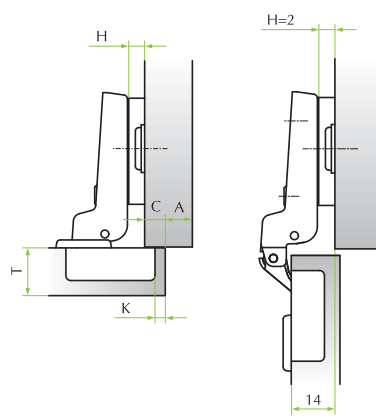

		Drilling distance (K)						
		3	4	5	6	7		
Overlay (C)	19			0		2		
	18		0		2			
	17	0		2		4		
	16		2		4			
	15	2		4		6		
	14		4		6			
	13	4		6				
	12		6					
11	6						Mounting plates (H)	

		Drilling distance (K)						
		3	4	5	6	7		
Overlay (C)	11			0		2		
	10		0		2			
	9	0		2		4		
	8		2		4			
	7	2		4		6		
	6		4		6			
	5	4		6				
	4		6					
3	6						Mounting plates (H)	

Table to determinate the minimum distance **A** so that a door with **T** thickness can open without protrusion from the cabinet and without interfering with adjacent doors.

T=	16	17	18	19	20	21	22	23	24	25	26
K=3 A=	0.90	1.40	1.90	2.40	3.00	3.60	4.25	4.90	5.55	6.20	6.80
K=4 A=	0.85	1.25	1.75	2.25	2.75	3.35	4.00	4.65	5.30	5.95	6.60
K=5 A=	0.80	1.10	1.60	2.10	2.55	3.15	3.75	4.45	5.05	5.70	6.35

MS Slide-On 175°



Technical specifications:

- Depth of the metal cup 11.3mm
- Cup diameter 35mm
- Opening 175°
- Possibility of door drilling (K) from 3 to 7 mm
- Thickness of the door (T) from 16 to 26 mm
- SlowMotion Delta solutions

CRANK 0



CRANK 8



I
A
D

51.MW15.S5.00.0

51.MW15.S5.00.C

51.MW15.S5.00.B

Available with premounted selftapping screws

51.MW15.M5.08.0

51.MW15.M5.08.C

51.MW15.M5.08.B



I
A
D

51.MW16.S5.00.M

51.MW16.S5.00.N

51.MW16.S5.00.E

51.MW16.M5.08.M

51.MW16.M5.08.N

51.MW16.M5.08.E



I
A
D

51.MW16.S5.00.*

51.MW16.S5.00.S

51.MW16.S5.00.B

* 0 = dowels Ø10mm / D = dowels Ø8mm

51.MW16.M5.08.*

51.MW16.M5.08.S

51.MW16.M5.08.B



I
A
D

51.MW18.S5.00.V

51.MW18.S5.00.U

51.MW18.S5.00.Z

51.MW18.M5.08.V

51.MW18.M5.08.U

51.MW18.M5.08.Z

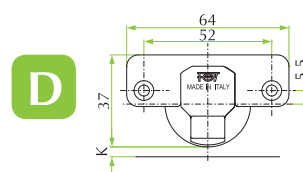
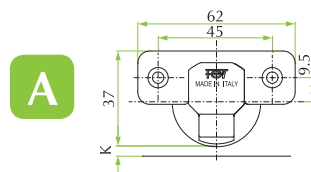
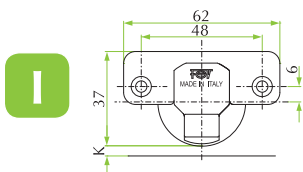

The mounting plates and fittings for this hinge series are shown from page 100 to page 107.

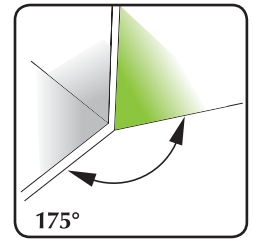
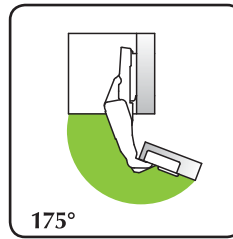

CRANK 0
For lay-on doors

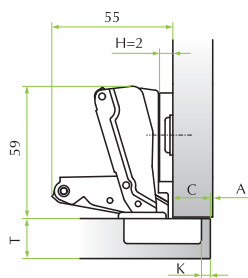

CRANK 8
For partial lay-on doors

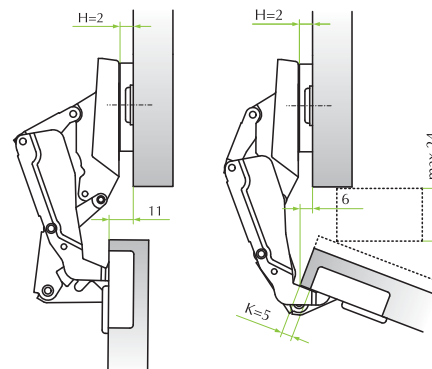
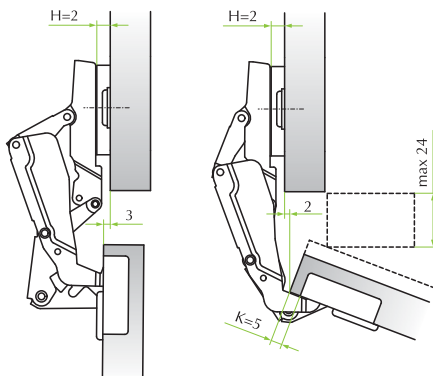
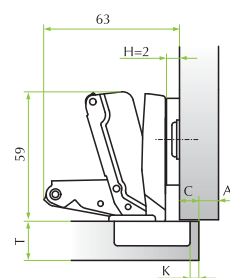

		Drilling distance (K)						
		3	4	5	6	7		
Overlay (C)	19			0	2			
	18		0	2				
	17	0	2	4				
	16	2	4	6				
	15	2	4	6				
	14	4	6					
	13	4	6					
	12	6						
11	6						Mounting plates (H)	

		Drilling distance (K)						
		3	4	5	6	7		
Overlay (C)	11			0	2			
	10		0	2				
	9	0	2	4				
	8	2	4	6				
	7	2	4	6				
	6	4	6					
	5	4	6					
	4	6						
3	6						Mounting plates (H)	

Table to determinate the minimum distance A so that a door with T thickness can open without protrusion from the cabinet and without interfering with adjacent doors.

T=	16	17	18	19	20	21	22	23	24	25	26
K=3 A=	0.00	0.00	0.00	0.00	0.00	0.00	0.20	0.55	6.80	8.10	13.55
K=4 A=	0.00	0.00	0.00	0.00	0.00	0.05	0.30	3.50	5.85	7.25	12.55
K=5 A=	0.00	0.00	0.00	0.00	0.00	0.05	0.30	3.55	4.90	6.25	11.55
K=6 A=	0.00	0.00	0.00	0.00	0.00	0.05	0.40	3.00	3.90	5.25	10.55
K=7 A=	0.00	0.00	0.00	0.00	0.00	0.05	1.20	2.20	3.15	4.25	9.55

MS Slide-On 95° Ø35 for thick doors



Technical specifications:

- Depth of the metal cup 11.3mm standard, 12.3mm Genios
- Cup diameter 35mm
- Opening 95°
- Possibility of door drilling (K) from 3 to 7 mm
- Thickness of the door (T) from 16 to 30 mm
- Genios solutions

CRANK 0



CRANK 4



CRANKS 8, 15
TO PAGE 78 >>>



I
A
D

51.MT15.05.00.0

51.MZ15.05.00.0 ●

51.MT15.05.04.0

51.MZ15.05.04.0 ●

51.MT15.05.00.C

51.MZ15.05.00.C ●

51.MT15.05.04.C

51.MZ15.05.04.C ●

51.MT15.05.00.B

51.MZ15.05.00.B ●

51.MT15.05.04.B

51.MZ15.05.04.B ●

Available with premounted selftapping screws



I
A
D

51.MT16.05.00.M

51.MZ16.05.00.M ●

51.MT16.05.04.M

51.MZ16.05.04.M ●

51.MT16.05.00.N

51.MZ16.05.00.N ●

51.MT16.05.04.N

51.MZ16.05.04.N ●

51.MT16.05.00.E

51.MZ16.05.00.E ●

51.MT16.05.04.E

51.MZ16.05.04.E ●



I
A
D

51.MT16.05.00.*

51.MZ16.05.00.0 ●

51.MT16.05.04.*

51.MZ16.05.04.0 ●

51.MT16.05.00.S

51.MZ16.05.00.S ●

51.MT16.05.04.S

51.MZ16.05.04.S ●

51.MT16.05.00.B

51.MZ16.05.00.B ●

51.MT16.05.04.B

51.MZ16.05.04.B ●

* 0 = dowels Ø10mm / D = dowels Ø8mm



I
A
D

51.MT18.05.00.V

51.MZ18.05.00.V ●

51.MT18.05.04.V

51.MZ18.05.04.V ●

51.MT18.05.00.U

51.MZ18.05.00.U ●

51.MT18.05.04.U

51.MZ18.05.04.U ●

51.MT18.05.00.Z

51.MZ18.05.00.Z ●

51.MT18.05.04.Z

51.MZ18.05.04.Z ●

● = G / Genios Solution

I

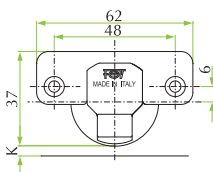

A

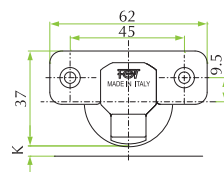

D

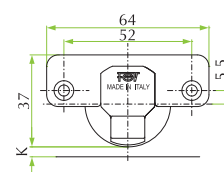

The mounting plates and fittings for this hinge series are shown from page 100 to page 107.

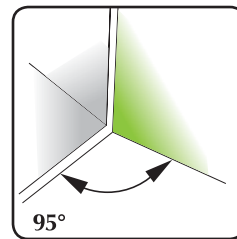
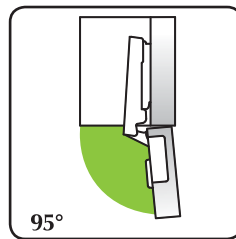

CRANK 0
For lay-on doors

CRANK 4
For partial lay-on doors

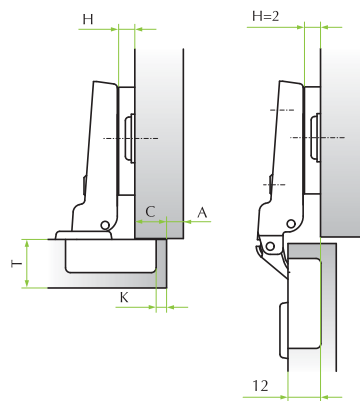
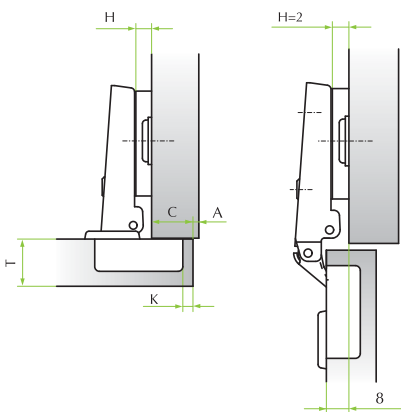

		Drilling distance (K)						
		3	4	5	6	7		
Overlay (C)	19			0		2		
	18		0		2			
	17	0		2		4		
	16		2		4			
	15	2		4		6		
	14		4		6			
	13	4		6				
12		6						
11	6							
		Mounting plates (H)						

		Drilling distance (K)						
		3	4	5	6	7		
Overlay (C)	15			0		2		
	14		0		2			
	13	0		2		4		
	12		2		4			
	11	2		4		6		
	10		4		6			
	9	4		6				
8		6						
7	6							
		Mounting plates (H)						

Table to determinate the minimum distance **A** so that a door with **T** thickness can open without protrusion from the cabinet and without interfering with adjacent doors.

T=	16	17	18	19	20	21	22	23	24	25	26	27	28	29	30
K=3 A=	0.00	0.15	0.35	0.5	0.7	0.85	1.15	1.65	2.55	3.40	4.30	5.20	6.15	7.10	8.00
K=4 A=	0.00	0.15	0.30	0.50	0.65	0.85	1.10	1.40	2.10	2.90	3.80	4.65	5.50	6.45	7.40
K=5 A=	0.00	0.15	0.30	0.50	0.65	0.80	1.00	1.35	1.75	2.50	3.30	4.15	5.00	5.90	6.75
K=6 A=	0.00	0.10	0.30	0.45	0.65	0.80	1.00	1.30	1.65	2.15	2.90	3.65	4.50	5.40	6.05
K=7 A=	0.00	0.10	0.30	0.45	0.60	0.80	0.95	1.25	1.60	1.90	2.55	3.30	4.05	4.90	5.75

MS Slide-On 95° Ø35 for thick doors



<<<CRANKS 0, 4 TO PAGE 76

CRANK 8

CRANK 15



I
A
D

51.MT15.05.08.0

51.MZ15.05.08.0 ●

51.MT15.05.15.0

51.MZ15.05.15.0 ●

51.MT15.05.08.C

51.MZ15.05.08.C ●

51.MT15.05.15.C

51.MZ15.05.15.C ●

51.MT15.05.08.B

51.MZ15.05.08.B ●

51.MT15.05.15.B

51.MZ15.05.15.B ●

Available with premounted selftapping screws



I
A
D

51.MT16.05.08.M

51.MZ16.05.08.M ●

51.MT16.05.15.M

51.MZ16.05.15.M ●

51.MT16.05.08.N

51.MZ16.05.08.N ●

51.MT16.05.15.N

51.MZ16.05.15.N ●

51.MT16.05.08.E

51.MZ16.05.08.E ●

51.MT16.05.15.E

51.MZ16.05.15.E ●



I
A
D

51.MT16.05.08.*

51.MZ16.05.08.0 ●

51.MT16.05.15.*

51.MZ16.05.15.0 ●

51.MT16.05.08.S

51.MZ16.05.08.S ●

51.MT16.05.15.S

51.MZ16.05.15.S ●

51.MT16.05.08.B

51.MZ16.05.08.B ●

51.MT16.05.15.B

51.MZ16.05.15.B ●

* 0 = dowels Ø10mm / D = dowels Ø8mm



I
A
D

51.MT18.05.08.V

51.MZ18.05.08.V ●

51.MT18.05.15.V

51.MZ18.05.15.V ●

51.MT18.05.08.U

51.MZ18.05.08.U ●

51.MT18.05.15.U

51.MZ18.05.15.U ●

51.MT18.05.08.Z

51.MZ18.05.08.Z ●

51.MT18.05.15.Z

51.MZ18.05.15.Z ●

● = G / Genios Solution

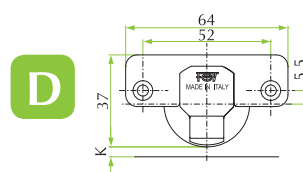
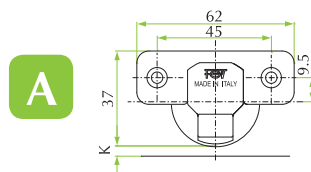
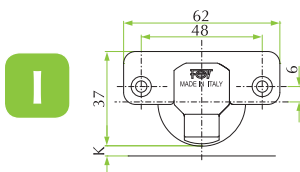

The mounting plates and fittings for this hinge series are shown from page 100 to page 107.

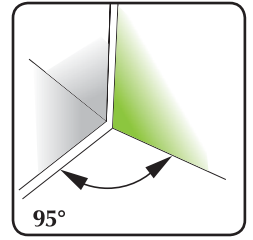
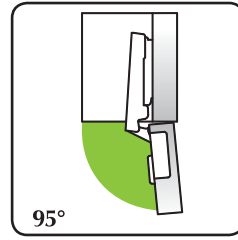

CRANK 8

For partial lay-on doors

CRANK 15

For inset doors

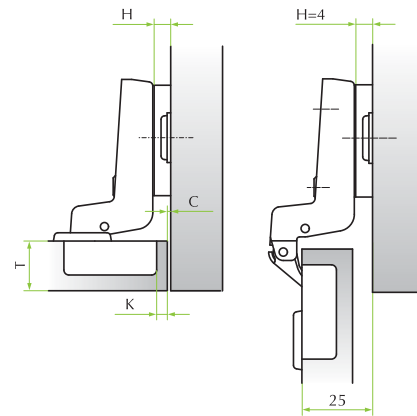
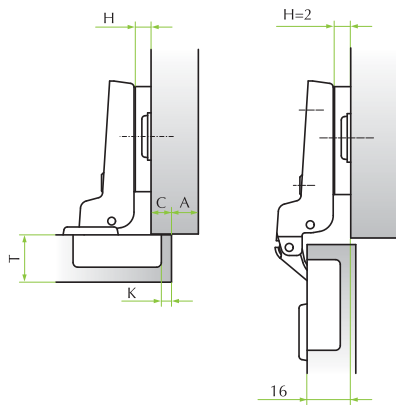

		Drilling distance (K)						
		3	4	5	6	7		
Overlay (C)	11			0		2		
	10		0		2			
	9	0		2		4		
	8		2		4			
	7	2		4		6		
	6		4		6			
	5	4		6				
	4		6					
3	6						Mounting plates (H)	

		Drilling distance (K)						
		3	4	5	6	7		
Overlay (C)	0	2		4		6		
	1		4		6			
	2	4		6				
	3		6					
	4	6						
								Mounting plates (H)

Table to determinate the minimum distance **A** so that a door with **T** thickness can open without protrusion from the cabinet and without interfering with adjacent doors.

T=	16	17	18	19	20	21	22	23	24	25	26	27	28	29	30
K=3 A=	0.00	0.15	0.35	0.5	0.7	0.85	1.15	1.65	2.55	3.40	4.30	5.20	6.15	7.10	8.00
K=4 A=	0.00	0.15	0.30	0.50	0.65	0.85	1.10	1.40	2.10	2.90	3.80	4.65	5.50	6.45	7.40
K=5 A=	0.00	0.15	0.30	0.50	0.65	0.80	1.00	1.35	1.75	2.50	3.30	4.15	5.00	5.90	6.75
K=6 A=	0.00	0.10	0.30	0.45	0.65	0.80	1.00	1.30	1.65	2.15	2.90	3.65	4.50	5.40	6.05
K=7 A=	0.00	0.10	0.30	0.45	0.60	0.80	0.95	1.25	1.60	1.90	2.55	3.30	4.05	4.90	5.75

MS Slide-On 110° for corner doors



Technical specifications:

- Depth of the metal cup 11.3mm
- Cup diameter 35mm
- Opening 110°
- Possibility of door drilling (K) from 3 to 7 mm
- Thickness of the door (T) from 16 to 26 mm
- OneTouch solutions

ANGLE -25°



ANGOLO +25°



ANGLES 24°÷30°, 45°, 90° TO PAGE 82 >>>



I
A
D

51.MK85.M5.25.0
51.MK85.M5.25.C
51.MK85.M5.25.B

Available with premounted selftapping screws

51.MS85.05.25.0
51.MS85.05.25.C
51.MS85.05.25.B



I
A
D

51.MK86.M5.25.M
51.MK86.M5.25.N
51.MK86.M5.25.E

51.MS86.05.25.M
51.MS86.05.25.N
51.MS86.05.25.E



I
A
D

51.MK86.M5.25.*
51.MK86.M5.25.S
51.MK86.M5.25.B

* 0 = dowels Ø10mm / D = dowels Ø8mm

51.MS86.05.25.*
51.MS86.05.25.S
51.MS86.05.25.B



I
A
D

51.MK88.M5.25.V
51.MK88.M5.25.U
51.MK88.M5.25.Z

51.MS88.05.25.V
51.MS88.05.25.U
51.MS88.05.25.Z

I

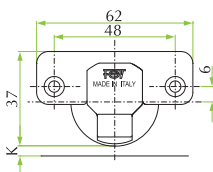

A

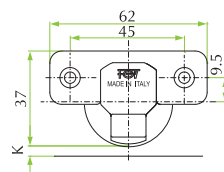

D

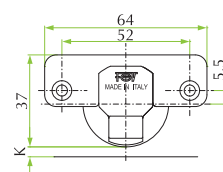

The mounting plates and fittings for this hinge series are shown from page 100 to page 107.

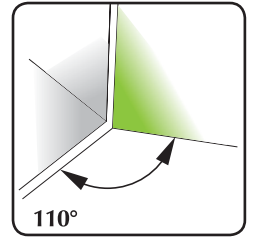
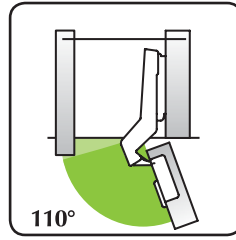

ANGLE -25°

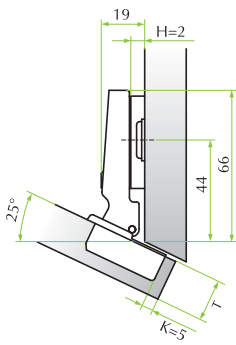

ANGLE -25°

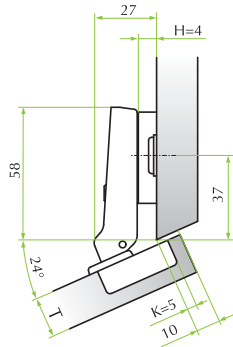

MS Slide-On 110° for corner doors



Technical specifications:

- Depth of the metal cup 11.3mm
- Cup diameter 35mm
- Opening 110°
- Possibility of door drilling (K) from 3 to 7 mm
- Thickness of the door (T) from 16 to 26 mm
- Genios, SlowMotion Alfa and OneTouch solutions

<<< ANGLES -25°, +25°
TO PAGE 80

ANGLE 24°÷30°

ANGLE 45°

ANGLE 90°



I
A
D

51.MS85.05.30.0 ●
51.MS85.05.30.C ●
51.MS85.05.30.B ●

51.MS85.M5.45.0 ●
51.MS85.M5.45.C ●
51.MS85.M5.45.B ●

51.MS85.M5.90.0 ●
51.MS85.M5.90.C ●
51.MS85.M5.90.B ●

Available with premounted selftapping screws



I
A
D

51.MS86.05.30.M ●
51.MS86.05.30.N ●
51.MS86.05.30.E ●

51.MS86.M5.45.M ●
51.MS86.M5.45.N ●
51.MS86.M5.45.E ●

51.MS86.M5.90.M ●
51.MS86.M5.90.N ●
51.MS86.M5.90.E ●



I
A
D

51.MS86.05.30.* ●
51.MS86.05.30.S ●
51.MS86.05.30.B ●

51.MS86.M5.45.* ●
51.MS86.M5.45.S ●
51.MS86.M5.45.B ●

51.MS86.M5.90.* ●
51.MS86.M5.90.S ●
51.MS86.M5.90.B ●

* 0 = dowels Ø10mm / D = dowels Ø8mm



I
A
D

51.MS88.05.30.V ●
51.MS88.05.30.U ●
51.MS88.05.30.Z ●

51.MS88.M5.45.V ●
51.MS88.M5.45.U ●
51.MS88.M5.45.Z ●

51.MS88.M5.90.V ●
51.MS88.M5.90.U ●
51.MS88.M5.90.Z ●



I
A
D

51.MS89.05.30.0 ●
51.MS89.05.30.S ●
51.MS89.05.30.B ●

51.MS89.M5.45.0 ●
51.MS89.M5.45.S ●
51.MS89.M5.45.B ●

51.MS89.M5.90.0 ●
51.MS89.M5.90.S ●
51.MS89.M5.90.B ●

● = G / Genios Solution

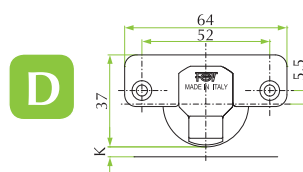
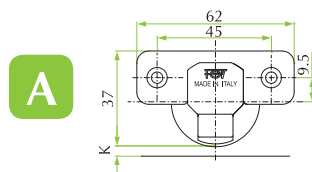
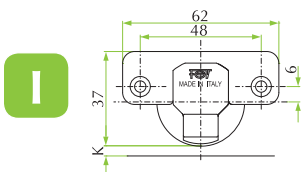

The mounting plates and fittings for this hinge series are shown from page 100 to page 107.

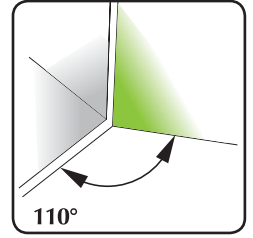
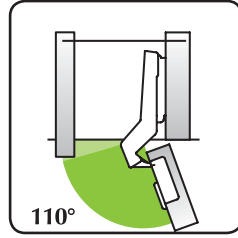

ANGLE 24°÷30°

ANGLE 45°

ANGLE 90°

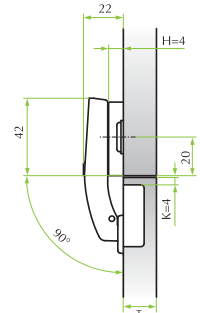
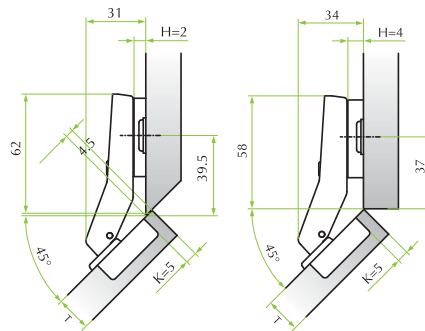
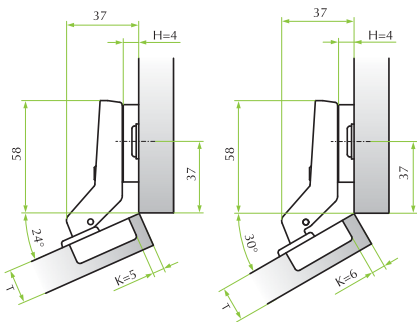

MS Slide-On for corner cabinet



Technical specifications:

- Depth of the metal cup 11.3mm
- Cup diameter 35mm
- Opening 110° with (K) max 4mm and (T) max 18mm
- Possibility of door drilling (K) from 3 to 7 mm
- Thickness of the door (T) from 16 to 26 mm



I
A
D

51.MS83.M5.35.0
51.MS83.M5.35.C
51.MS83.M5.35.B

Available with premounted selftapping screws



I
A
D

51.MS84.M5.35.M
51.MS84.M5.35.N
51.MS84.M5.35.E



I
A
D

51.MS84.M5.35.*
51.MS84.M5.35.S
51.MS84.M5.35.B

* 0 = dowels Ø10mm / D = dowels Ø8mm



I
A
D

51.MS88.M5.35.V
51.MS88.M5.35.U
51.MS88.M5.35.Z

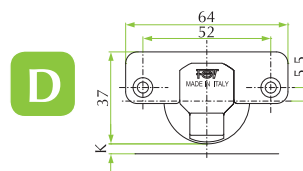
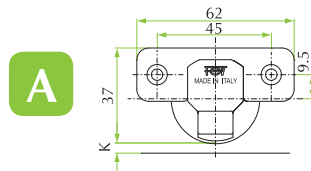
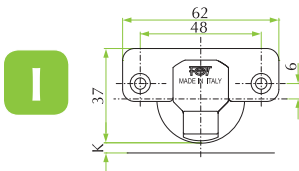

The mounting plates and fittings for this hinge series are shown from page 100 to page 107.

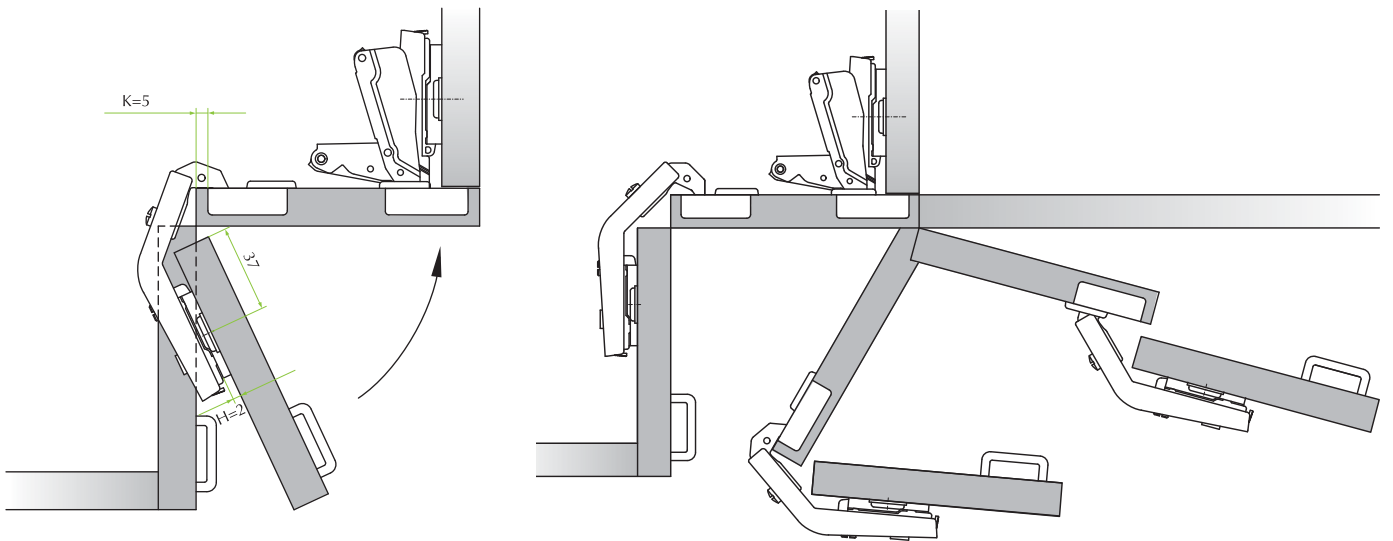
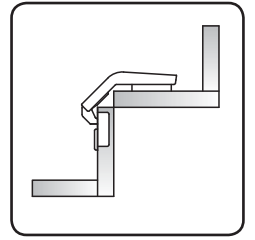

MS Slide-On 90° Ø40 for thick doors



Technical specifications:

- Depth of the metal cup 12.8mm
- Cup diameter 40mm
- Opening 90°
- Possibility of door drilling (K) from 3 to 15 mm
- Thickness of the door (T) from 16 to 40 mm
- OneTouch solutions

CRANK 0

CRANK 8

CRANKS 15, 22 TO PAGE 88 >>>

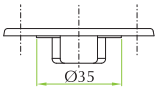

S

51.MN45.05.00.0

51.MN45.05.08.0

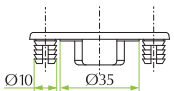

S

51.MN46.05.00.0

51.MN46.05.08.0

CRANK 0

For lay-on doors

CRANK 8

For partial lay-on doors

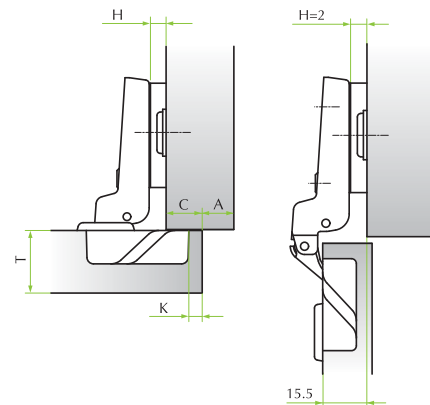
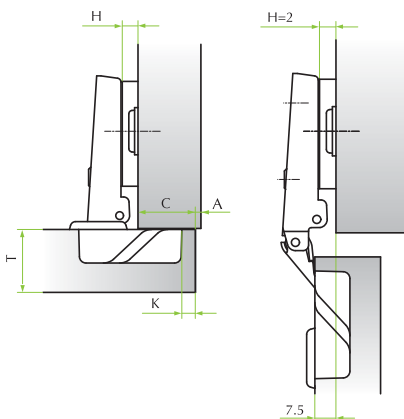

CUP HOLE DISTANCE 52x7.5mm

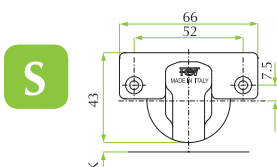

The mounting plates and fittings for this hinge series are shown from page 100 to page 107.

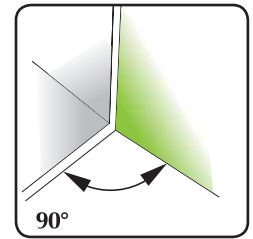
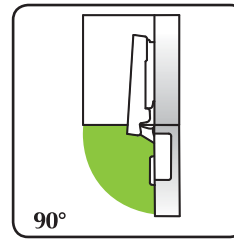

CRANK 0
For lay-on doors

		Drilling distance (K)													
		4	5	6	7	8	9	10	11	12	13	14	15		
Overlay (C)	32										0	2			
	31									0	2				
	30								0	2	4				
	29							0	2	4	6				
	28					0	2	4	6						
	27				0	2	4	6							
	26			0	2	4	6								
	25		0	2	4	6									
	24	0	2	4	6										
	23	0	2	4	6										
	22	2	4	6											
	21	2	4	6											
	20	4	6												
	19	4	6												
	18	6													
17	6														
Mounting plates (H)															

CRANK 8
For partial lay-on doors

		Drilling distance (K)													
		4	5	6	7	8	9	10	11	12	13	14	15		
Overlay (C)	24										0	2			
	23									0	2				
	22								0	2	4				
	21						0	2	4	6					
	20					0	2	4	6						
	19				0	2	4	6							
	18			0	2	4	6								
	17		0	2	4	6									
	16	0	2	4	6										
	15	0	2	4	6										
	14	2	4	6											
	13	2	4	6											
	12	4	6												
	11	4	6												
	10	6													
9	6														
Mounting plates (H)															

Table to determinate the minimum distance **A** so that a door with **T** thickness can open without protrusion from the cabinet and without interfering with adjacent doors.

T=	20	21	22	23	24	25	26	27	28	29	30	31	32	33	34	35	36	37	38	39	40
K=3 A=	0.20	0.35	0.55	0.70	0.9	1.05	1.25	1.40	1.60	2.25	3.20	4.15	5.05	6.05	7.00	8.00	9.00	9.95	10.95	11.95	12.95
K=4 A=	0.20	0.35	0.50	0.70	0.85	1.05	1.20	1.40	1.55	1.75	2.55	3.45	4.40	5.35	6.30	7.25	8.15	9.15	10.15	11.10	12.10
K=5 A=	0.15	0.35	0.50	0.70	0.85	1.05	1.20	1.40	1.55	1.70	2.05	2.80	3.75	4.70	5.65	6.55	7.50	8.45	9.40	10.35	11.25
K=6 A=	0.15	0.30	0.50	0.65	0.85	1.00	1.20	1.35	1.55	1.70	2.00	2.30	3.10	4.05	4.95	5.90	6.85	7.80	8.75	9.65	10.60
K=7 A=	0.15	0.30	0.50	0.65	0.85	1.00	1.15	1.35	1.50	1.70	1.90	2.25	2.60	3.50	4.35	5.25	6.20	7.15	8.05	9.00	9.95
K=8 A=	0.10	0.30	0.45	0.65	0.8	1.00	1.15	1.35	1.50	1.70	1.85	2.20	2.55	3.00	3.85	4.70	5.60	6.50	7.40	8.35	9.30
K=9 A=	0.10	0.25	0.45	0.60	0.8	0.95	1.15	1.30	1.50	1.65	1.85	2.15	2.50	2.80	3.35	4.20	5.10	5.95	6.80	7.70	8.65
K=10 A=	0.10	0.25	0.45	0.60	0.8	0.95	1.15	1.30	1.50	1.65	1.85	2.10	2.40	2.75	3.10	3.70	4.60	5.45	6.30	7.20	8.05
K=11 A=	0.05	0.25	0.40	0.60	0.75	0.95	1.10	1.30	1.45	1.60	1.80	2.00	2.35	2.70	3.05	3.40	4.10	4.95	5.80	6.70	7.55
K=12 A=	0.05	0.25	0.40	0.60	0.75	0.90	1.10	1.25	1.45	1.60	1.80	1.95	2.30	2.65	3.00	3.35	3.75	4.50	5.30	6.20	7.05
K=13 A=	0.05	0.20	0.40	0.55	0.75	0.90	1.10	1.25	1.45	1.60	1.80	1.95	2.25	2.60	2.90	3.25	3.60	4.15	4.90	5.70	6.55
K=14* A=	0.05	0.20	0.40	0.55	0.70	0.90	1.05	1.25	1.40	1.60	1.75	1.95	2.10	2.50	2.85	3.20	3.55	3.90	4.55	5.35	6.05
K=15* A=	0.00	0.02	0.35	0.55	0.70	0.90	1.05	1.25	1.40	1.55	1.75	1.90	2.10	2.45	2.80	3.15	3.50	3.85	4.25	4.95	5.75

* L= 0,77 • L= 1,76

MS Slide-On 90° Ø40 for thick doors



<<< CRANKS 0, 8
TO PAGE 86

CRANK 15

CRANK 22

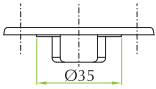

51.MN45.05.15.0

51.MN45.05.22.0

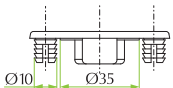

51.MN46.05.15.0

51.MN46.05.22.0

CRANK 15
For lay-on doors

CRANK 22
For partial lay-on doors

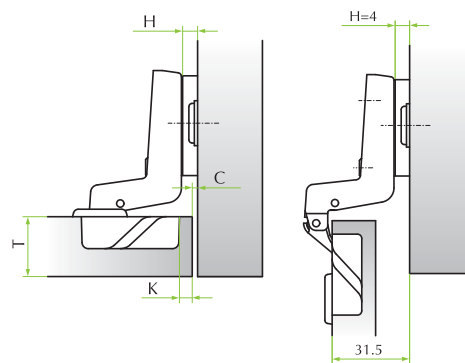
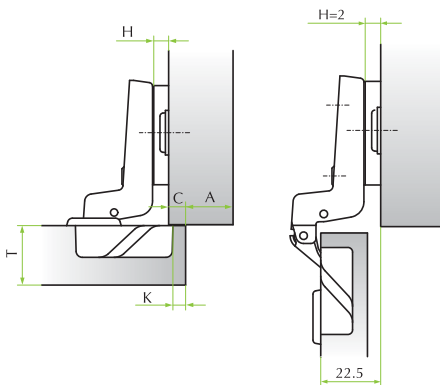

CUP HOLE DISTANCE 52x7.5mm

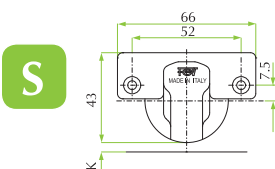

The mounting plates and fittings for this hinge series are shown from page 100 to page 107.

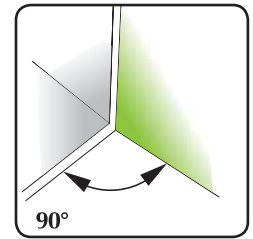
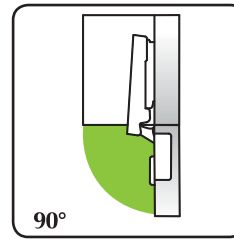

CRANK 15
For lay-on doors

		Drilling distance (K)													
		4	5	6	7	8	9	10	11	12	13	14	15		
Overlay (C)	17										0	2			
	16									0	2				
	15								0	2	4				
	14							0	2	4	6				
	13					0	2	4	6						
	12				0	2	4	6							
	11			0	2	4	6								
	10		0	2	4	6									
	9	0	2	4	6										
	8	0	2	4	6										
	7	2	4	6											
	6	2	4	6											
	5	4	6												
	4	4	6												
	3	6													
	2	6													

Mounting plates (H)

CRANK 22
For partial lay-on doors

		Drilling distance (K)									
		4	5	6	7	8	9	10			
Overlay (C)	0		2	4	6						
	1	2	4	6							
	2	4	6								
	3	4	6								
	4	6									
	5	6									
	6										

Mounting plates (H)

Table to determinate the minimum distance **A** so that a door with **T** thickness can open without protrusion from the cabinet and without interfering with adjacent doors.

T=	20	21	22	23	24	25	26	27	28	29	30	31	32	33	34	35	36	37	38	39	40
K=3 A=	0.20	0.35	0.55	0.70	0.9	1.05	1.25	1.40	1.60	2.25	3.20	4.15	5.05	6.05	7.00	8.00	9.00	9.95	10.95	11.95	12.95
K=4 A=	0.20	0.35	0.50	0.70	0.85	1.05	1.20	1.40	1.55	1.75	2.55	3.45	4.40	5.35	6.30	7.25	8.15	9.15	10.15	11.10	12.10
K=5 A=	0.15	0.35	0.50	0.70	0.85	1.05	1.20	1.40	1.55	1.70	2.05	2.80	3.75	4.70	5.65	6.55	7.50	8.45	9.40	10.35	11.25
K=6 A=	0.15	0.30	0.50	0.65	0.85	1.00	1.20	1.35	1.55	1.70	2.00	2.30	3.10	4.05	4.95	5.90	6.85	7.80	8.75	9.65	10.60
K=7 A=	0.15	0.30	0.50	0.65	0.85	1.00	1.15	1.35	1.50	1.70	1.90	2.25	2.60	3.50	4.35	5.25	6.20	7.15	8.05	9.00	9.95
K=8 A=	0.10	0.30	0.45	0.65	0.8	1.00	1.15	1.35	1.50	1.70	1.85	2.20	2.55	3.00	3.85	4.70	5.60	6.50	7.40	8.35	9.30
K=9 A=	0.10	0.25	0.45	0.60	0.8	0.95	1.15	1.30	1.50	1.65	1.85	2.15	2.50	2.80	3.35	4.20	5.10	5.95	6.80	7.70	8.65
K=10 A=	0.10	0.25	0.45	0.60	0.8	0.95	1.15	1.30	1.50	1.65	1.85	2.10	2.40	2.75	3.10	3.70	4.60	5.45	6.30	7.20	8.05
K=11 A=	0.05	0.25	0.40	0.60	0.75	0.95	1.10	1.30	1.45	1.60	1.80	2.00	2.35	2.70	3.05	3.40	4.10	4.95	5.80	6.70	7.55
K=12 A=	0.05	0.25	0.40	0.60	0.75	0.90	1.10	1.25	1.45	1.60	1.80	1.95	2.30	2.65	3.00	3.35	3.75	4.50	5.30	6.20	7.05
K=13 A=	0.05	0.20	0.40	0.55	0.75	0.90	1.10	1.25	1.45	1.60	1.80	1.95	2.25	2.60	2.90	3.25	3.60	4.15	4.90	5.70	6.55
K=14* A=	0.05	0.20	0.40	0.55	0.70	0.90	1.05	1.25	1.40	1.60	1.75	1.95	2.10	2.50	2.85	3.20	3.55	3.90	4.55	5.35	6.05
K=15* A=	0.00	0.02	0.35	0.55	0.70	0.90	1.05	1.25	1.40	1.55	1.75	1.90	2.10	2.45	2.80	3.15	3.50	3.85	4.25	4.95	5.75

* L= 0,77 • L= 1,76

MS Slide-On 90° Ø26 for wood doors



Technical specifications:

- Depth of the metal cup 11.7mm
- Cup diameter 26mm
- Opening 90°
- Possibility of door drilling (K) from 3 to 5 mm
- Thickness of the door (T) from 16 to 26 mm

CRANK 0



CRANK 8



CRANK 15

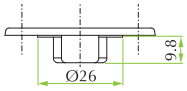

51.MG15.05.00.0

51.MG15.05.08.0

51.MG15.05.15.0

Available with premounted selftapping screws

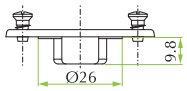

51.MG16.05.00.M

51.MG16.05.08.M

51.MG16.05.15.M

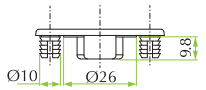

51.MG16.05.00.*

51.MG16.05.08.*

51.MG16.05.15.*

* 0 = dowels Ø10mm / D = dowels Ø8mm

CUP HOLE DISTANCE 38x8mm

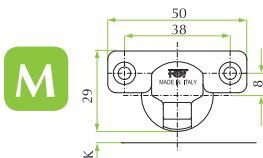

The mounting plates and fittings for this hinge series are shown from page 100 to page 107.

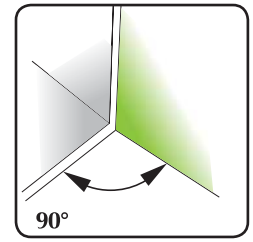
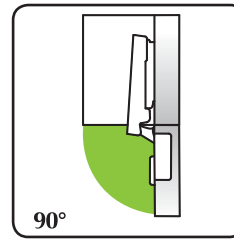

CRANK 0
For lay-on doors

CRANK 8
For partial lay-on doors

CRANK 15
For inset doors

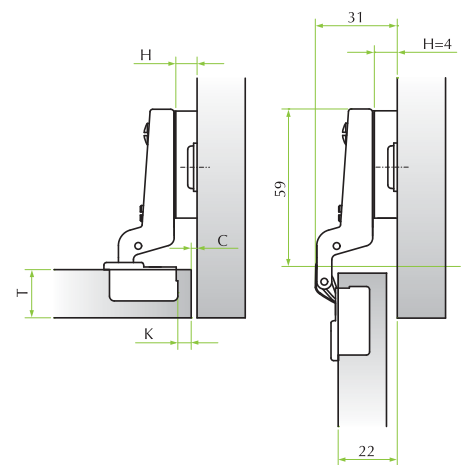
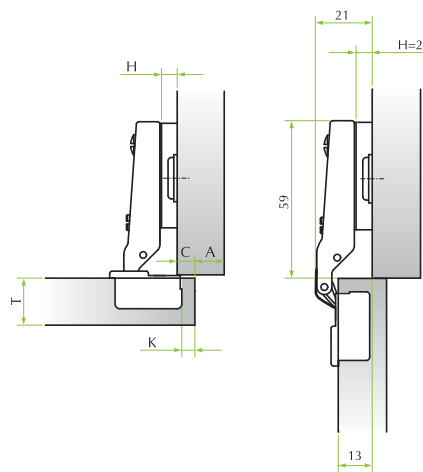
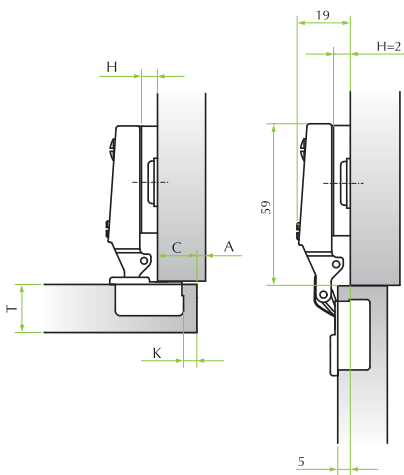

		Drilling distance (K)									
		3	4	5	6						
Overlay (C)	19				0						
	18				0						
	17		0		2						
	16	0		2							
	15		2		4						
	14		2	4							
	13		4		6						
	12		4		6						
	11		6								
10	6										
Mounting plates (H)											

		Drilling distance (K)									
		3	4	5	6						
Overlay (C)	11				0						
	10				0						
	9		0		2						
	8	0		2							
	7		2		4						
	6		2	4							
	5		4		6						
	4		4		6						
	3		6								
	2	6									
	Mounting plates (H)										

		Drilling distance (K)									
		3	4	5	6						
Overlay (C)	0		2		4						
	1	2			4						
	2		4		6						
	3		4		6						
	4		6								
	5		6								
Mounting plates (H)											

Table to determine the minimum distance **A** so that a door with **T** thickness can open without protrusion from the cabinet and without interfering with adjacent doors.

		T=	16	17	18	19	20	21	22	23	24	25	26
K=3	A=		0.80	1.45	2.15	3.10	3.90	4.85	5.75	6.70	7.65	8.60	9.55
K=4	A=		0.75	1.25	1.75	2.55	3.30	4.20	5.10	6.05	7.00	7.95	8.85
K=5	A=		0.65	1.05	1.40	2.20	2.95	3.75	4.55	5.45	6.35	7.25	8.20

MS Slide-On 90° Ø26 for glass doors



Technical specifications:

- Thickness of the glass doors (T) from 4 to 5 mm
- Cup diameter 26mm
- Opening 90°
- Possibility of door drilling (K) from 3 to 5 mm

CRANK 0



CRANK 8



CRANK 15

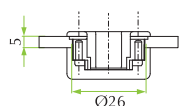

NYLON
(glass)



51.MG11.2*.00.0

51.MG11.2*.08.0

51.MG11.2*.15.0

* 1 = White / 3 = Black

NYLON (glass)

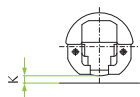

The mounting plates and fittings for this hinge series are shown from page 100 to page 107.

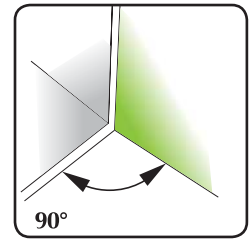
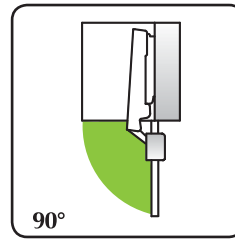

CRANK 0
For lay-on doors

CRANK 8
For partial lay-on doors

CRANK 15
For inset doors

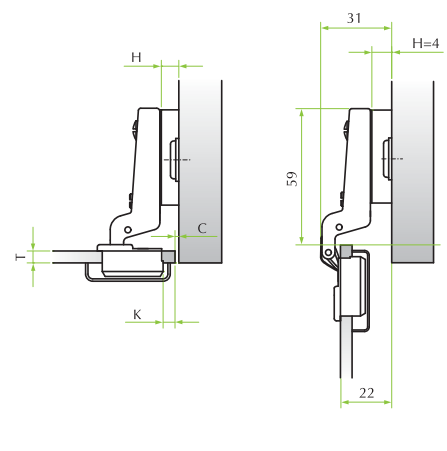
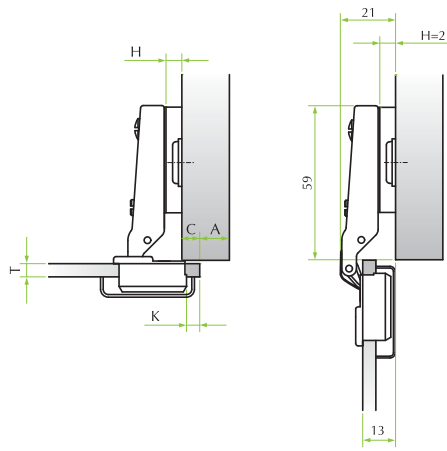
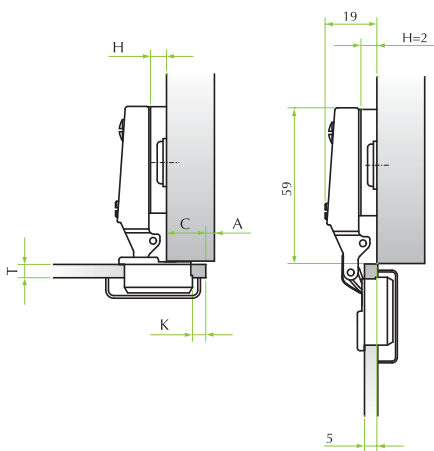

		Drilling distance (K)					
		3	4	5	6		
Overlay (C)	19				0		
	18			0			
	17		0	2			
	16	0	2				
	15	2	4				
	14	4	6				
	13	6					
	12						
	11						
10	6						
							Mounting plates (H)

		Drilling distance (K)					
		3	4	5	6		
Overlay (C)	11				0		
	10			0			
	9		0	2			
	8	0	2				
	7	2	4				
	6	4	6				
	5	6					
	4						
	3						
	2	6					

		Drilling distance (K)					
		3	4	5	6		
Overlay (C)	0		2	4			
	1	2	4				
	2	4	6				
	3	6					
	4						
	5						
							Mounting plates (H)

Table to determine the minimum distance **A** so that a door with **T** thickness can open without protrusion from the cabinet and without interfering with adjacent doors.

	T=	16	17	18	19	20	21	22	23	24	25	26
K=3	A=	0.80	1.45	2.15	3.10	3.90	4.85	5.75	6.70	7.65	8.60	9.55
K=4	A=	0.75	1.25	1.75	2.55	3.30	4.20	5.10	6.05	7.00	7.95	8.85
K=5	A=	0.65	1.05	1.40	2.20	2.95	3.75	4.55	5.45	6.35	7.25	8.20

MS Slide-On 105° for doors with aluminium frame



Technical specifications:

- Depth of the zamak cup 9.9mm
- Cup drilling 28x7mm
- Opening 105°
- Aluminium frame from min. 19 to max 25 mm
- Genios and OneTouch solutions

FIXING FOR GROOVED PROFILE

CRANK 0



51.MS41.05.00.0 ●

CRANK 8



51.MS41.05.08.0 ●

CRANK 15



51.MS41.05.15.0 ●

● = G / Genios Solution

Drilling holes:

The two laterals drillings are $\varnothing 4$ mm and are countersunk with 120°. Screws 3.5x12mm supplied on demand under code 1A05512105000.

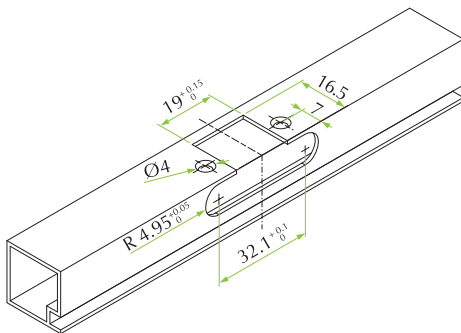

Assembly instructions:

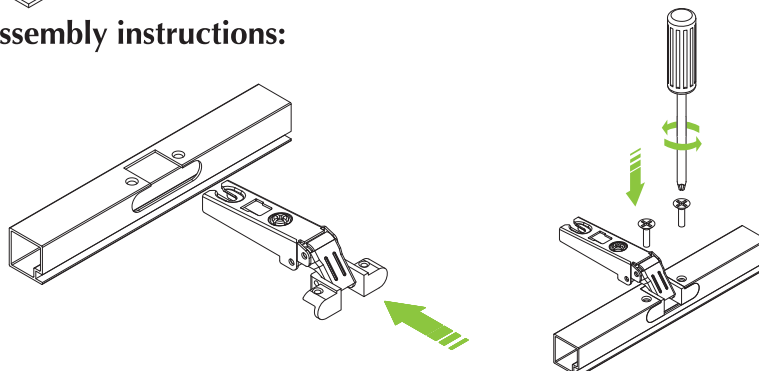

The mounting plates and fittings for this hinge series are shown from page 100 to page 107.

MS Slide-On 105° for doors with aluminium frame



Technical specifications:

- Depth of the zamak cup 9.9mm
- Opening 105°
- Aluminium frame from min. 19 to max 25 mm

LOCK FIXING

CRANK 0



51.MS31.05.00.0

CRANK 8



51.MS31.05.08.0

CRANK 15



51.MS31.05.15.0

Aluminium frame:

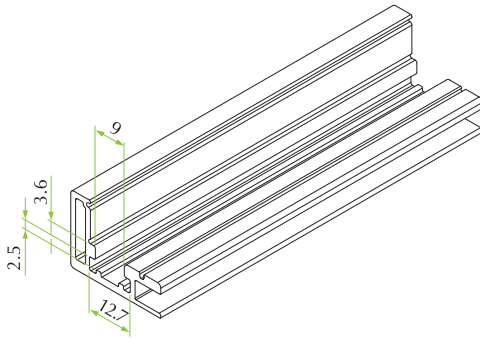

Assembly instructions:

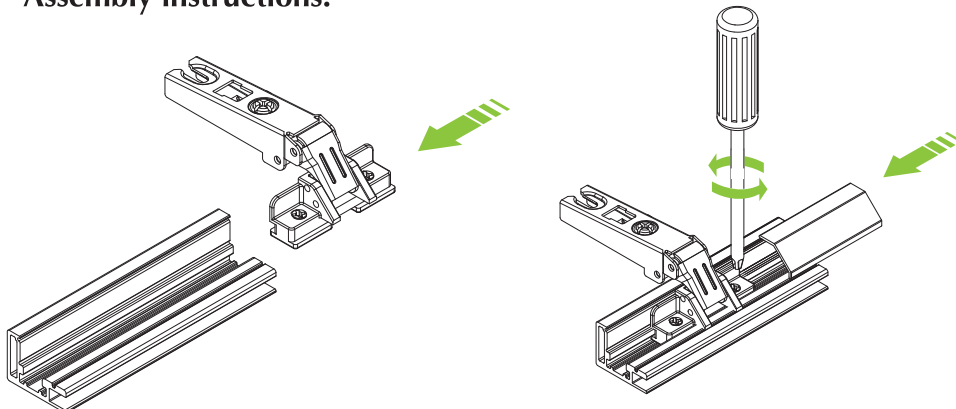

The mounting plates and fittings for this hinge series are shown from page 100 to page 107.

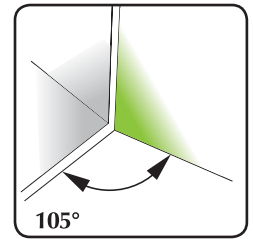
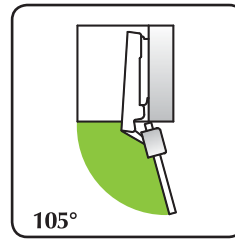

CRANK 0
For lay-on doors

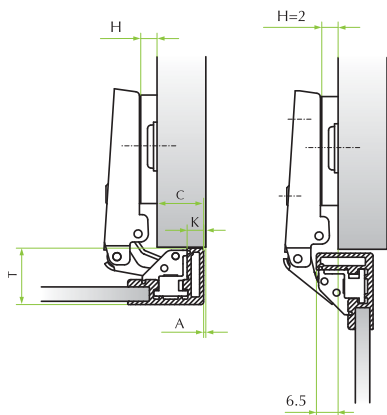

CRANK 8
For partial lay-on doors

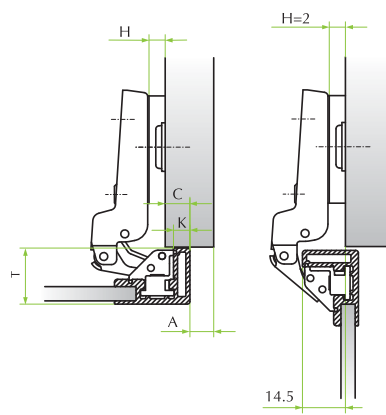

CRANK 15
For inset doors

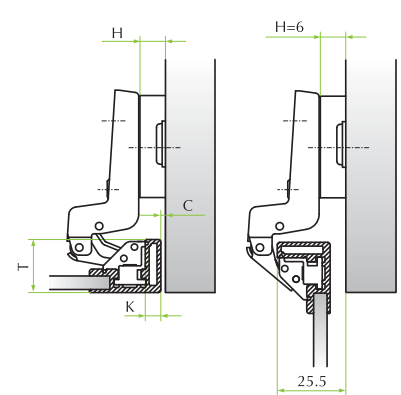

		Drilling distance (K)						
		3	4	5	6	7		
Overlay (C)	19					2		
	18				2			
	17			2		4		
	16		2		4			
	15	2		4		6		
	14		4		6			
	13			4		6		
	12				6			
11	6							

Mounting plates (H)

		Drilling distance (K)						
		3	4	5	6	7		
Overlay (C)	11					2		
	10				2			
	9			2		4		
	8		2		4			
	7	2		4		6		
	6		4		6			
	5			4		6		
	4				6			
3	6							

Mounting plates (H)

		Drilling distance (K)						
		3	4	5	6	7		
Overlay (C)	0	2		4		6		
	1		4		6			
	2	4		6				
	3		6					
	4	6						

Mounting plates (H)

Table to determinate the minimum distance **A** so that a door with **T** thickness can open without protrusion from the cabinet and without interfering with adjacent doors.

T=		16	17	18	19	20	22	23	24	25	26	27
K=3	A=	0.55	0.75	1.10	1.45	1.80	2.40	3.10	3.90	4.70	6.70	6.50
K=4	A=	0.55	0.70	1.05	1.40	1.75	2.25	2.85	3.60	4.35	5.75	6.00
K=5	A=	0.53	0.70	1.00	1.35	1.65	2.10	2.65	3.30	4.00	4.75	5.55
K=6	A=	0.50	0.70	0.95	1.25	1.60	2.00	2.50	3.05	3.70	4.40	5.20
K=7	A=	0.50	0.65	0.85	1.20	1.55	1.90	2.35	2.85	3.45	4.10	4.80

MS Slide-On 95° for flap doors



Technical specifications:

- Depth of the metal cup 11.3mm
- Cup diameter 35mm
- Possibility of door drilling (K) from 3 to 7 mm
- Thickness of the door (T) from 16 to 26 mm

LEFT



51.MN57.L9.00000

RIGHT



51.MN57.R9.00000

Drilling holes:

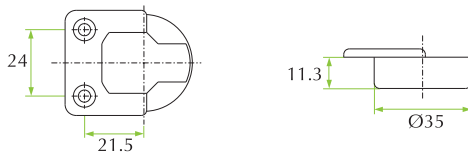

Assembly instructions:

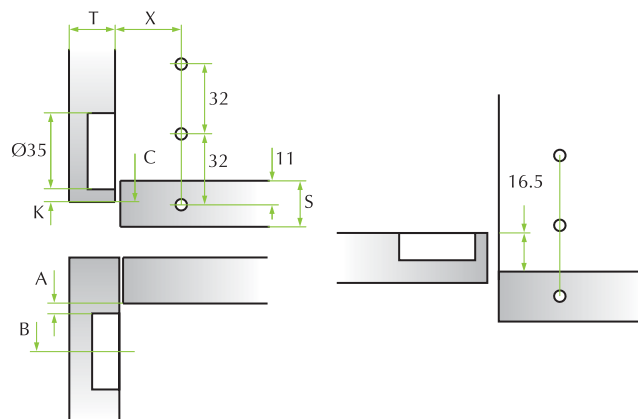

The mounting plates and fittings for this hinge series are shown from page 100 to page 107.

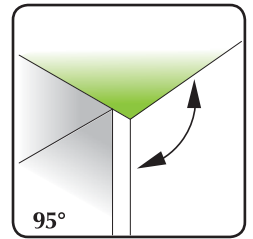
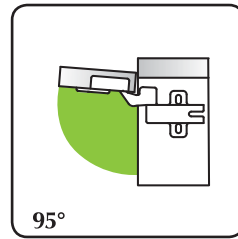
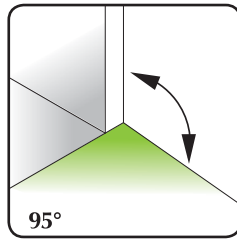
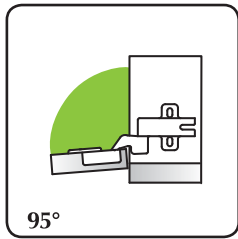

DOWN SOLUTION

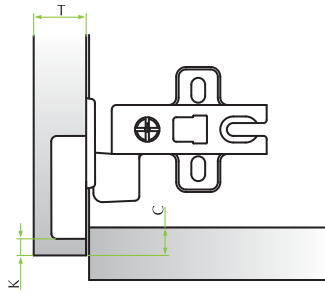

UP SOLUTION

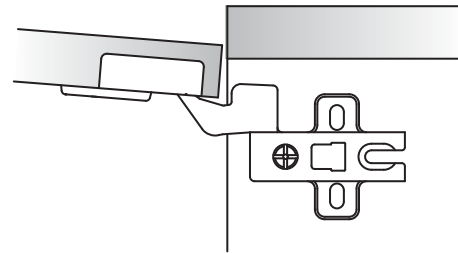
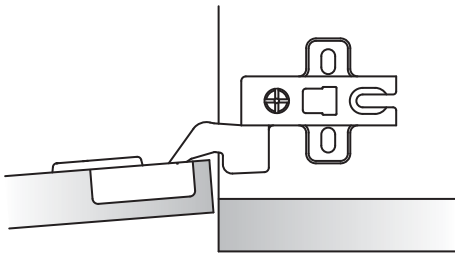
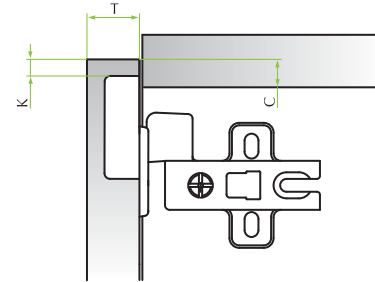

K	C	H	A	B
3	4.5	2	2.5	20
4	5.5	4	4.5	22
5	6.5	6	6.5	24
6	7.5			
7	8.5			

Series MS Slide-On

HOW TO CHOOSE YOUR MOUNTING PLATE

GENIOS **R**  SLIDE-ON RETROFIT MOUNTING PLATE

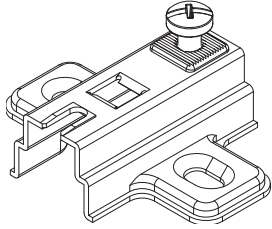

SLIDE-ON GENIOS DAMPER



GENIOS **G** SLIDE-ON INTEGRATED MOUNTING PLATE

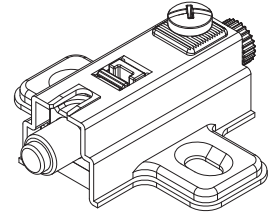

Genios Slide-On damper for Genios Slide-On Retrofit mounting plate.







Height	Code
H=2	59.050G.10.02.00000
H=4	59.050G.10.04.00000
H=6	59.050G.10.06.00000

Metal cruciform mounting plate. Selftapping screw fixing. Vertical adjustment.
Screws are provided on demand.

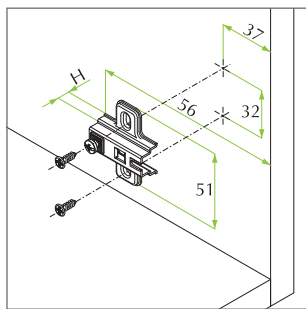

37



Height	Material	Code
H=0	Steel	52.C201.M5.00.1
H=2	Steel	52.0201.M5.02.1 
H=4	Steel	52.0201.M5.04.1 
H=6	Steel	52.0201.M5.06.1 
H=10	Zamak	52.0201.05.10.1



 = R / Genios Retrofit Solution
G / Genios Integrated Solution

Metal cruciform mounting plate. Euro screws premounted. Vertical adjustment.

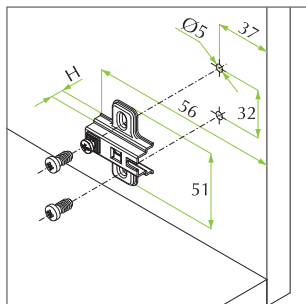

37



Height	Material	Code
H=0	Steel	52.C216.M5.00.*
H=2	Steel	52.0216.M5.02.* 
H=4	Steel	52.0216.M5.04.* 
H=6	Steel	52.0216.M5.06.* 
H=10	Zamak	52.0216.05.10.*
H=24	Zamak	52.0216.05.24.*

* C =  D =  H =   = R / Genios Retrofit Solution
G / Genios Integrated Solution

Metal cruciform mounting plate. Premounted selftapping screws Ø4.7mm. Vertical adjustment.

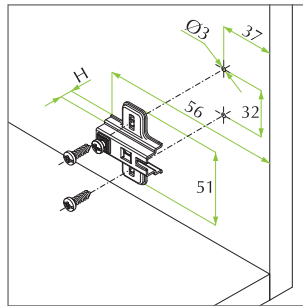

Height	Material	Code
H=0	Steel	52.C2G5.M5.00.1
H=2	Steel	52.02G5.M5.02.1 ●
H=4	Steel	52.02G5.M5.04.1 ●
H=6	Steel	52.02G5.M5.06.1 ●

● = R / Genios Retrofit Solution
G / Genios Integrated Solution

Metal cruciform mounting plate. Fixing by expanding X-Pando dowels Ø5mm. Vertical adjustment.

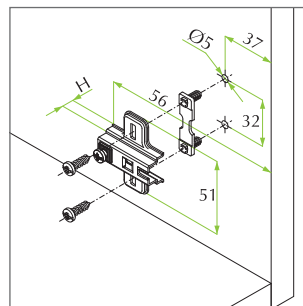

Height	Material	Code
H=0	Steel	52.C2N5.M5.00.*
H=2	Steel	52.02N5.M5.02.* ●
H=4	Steel	52.02N5.M5.04.* ●
H=6	Steel	52.02N5.M5.06.* ●
H=10	Zamak	52.02N5.05.10.*

* 1 = 9.2 3 = 7.5 ● = R / Genios Retrofit Solution
G / Genios Integrated Solution
Available only for dowel 9.2

Metal cruciform mounting plate. Knock-in fixing with dowels Ø8mm. Vertical adjustment.

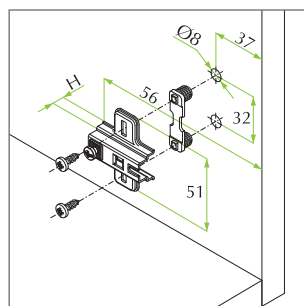

Height	Material	Code
H=0	Steel	52.C2*5.M5.00.1
H=2	Steel	52.02*5.M5.02.1 ●
H=4	Steel	52.02*5.M5.04.1 ●
H=6	Steel	52.02*5.M5.06.1 ●
H=10	Zamak	52.02*5.05.10.1

* C = 10.8 E = 7.5 ● = R / Genios Retrofit Solution
G / Genios Integrated Solution
Available only for dowel 10.8

Metal cruciform mounting plate. Knock-in fixing with dowels Ø10mm. Vertical adjustment.

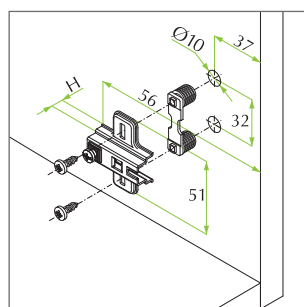

Height	Material	Code
H=0	Steel	52.C2*5.M5.00.1
H=2	Steel	52.02*5.M5.02.1 ●
H=4	Steel	52.02*5.M5.04.1 ●
H=6	Steel	52.02*5.M5.06.1 ●
H=10	Zamak	52.02*5.05.10.1

* D = 10.8 F = 8.5 ● = R / Genios Retrofit Solution
G / Genios Integrated Solution
Available only for dowel 10.8

Series MS Slide-On

Asymmetric mounting plate for central panel. Fixing by dowels and selftapping screws. Vertical adjustment.

37

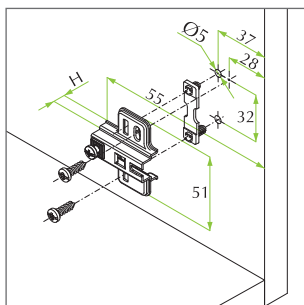

Height	Material	Code
H=2	Steel	52.52N7.M5.02.1
H=4	Steel	52.52N7.M5.04.1

Metal cruciform mounting plate. Euro screws premounted. Vertical adjustment.

28

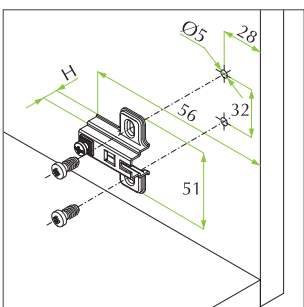

Height	Material	Code
H=4	Steel	52.0221.M5.04.*

* C = D = H =

Metal cruciform mounting plate. Premounted selftapping screws Ø4.7mm. Vertical adjustment.

28

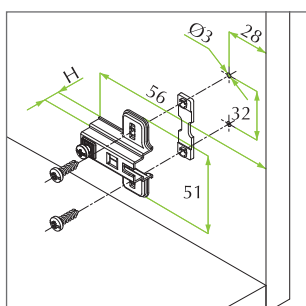

Height	Material	Code
H=4	Steel	52.02G1.M5.04.1

Metal cruciform mounting plate. Fixing by expanding X-Pando dowels Ø5mm. Vertical adjustment.

28

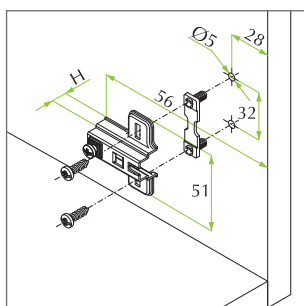

Height	Material	Code
H=4	Steel	52.02N1.M5.04.*

* 1 = 3 =

Metal cruciform mounting plate. Knock-in fixing with dowels Ø8mm. Vertical adjustment.

28

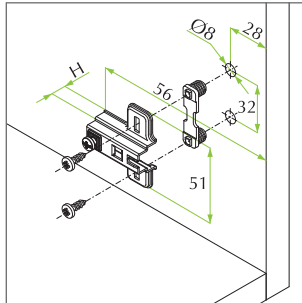

Height	Material	Code
H=4	Steel	52.02C1.M5.04.1

Metal cruciform mounting plate. Knock-in fixing with dowels Ø10mm. Vertical adjustment.

28

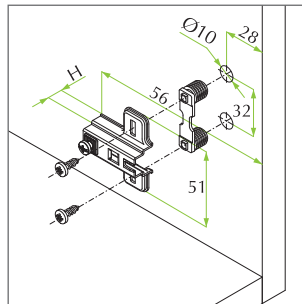

Height	Material	Code
H=4	Steel	52.02D1.M5.04.1

Asymmetric mounting plate for central panel. Fixing by dowels and selftapping screws. Vertical adjustment.

28

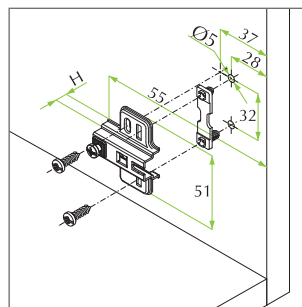

Height	Material	Code
H=2	Steel	52.52N3.M5.02.1
H=4	Steel	52.52N3.M5.04.1

Zamak cruciform mounting plate with 30° inclination. Euro screws premounted. Vertical adjustment.

28

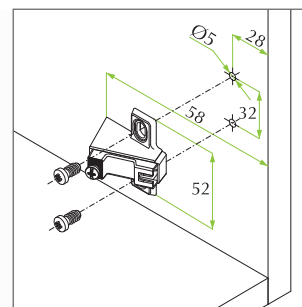

Angolo	Material	Code
30°	Zamak	52.0266.05.24.*

* C = 14 D = 12 H = 01

Series MS Slide-On

Zamak linear mounting plate. Knock-in fixing with dowels $\text{\O}8\text{mm}$. Independent vertical adjustment.

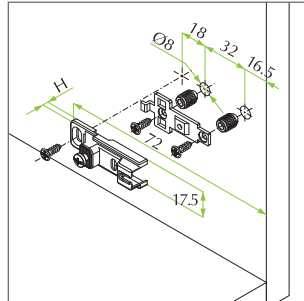

<u>Height</u>	<u>Material</u>	<u>Code</u>
<u>H=2</u>	<u>Zamak</u>	<u>52.0209.05.02.1</u>

Zamak linear mounting plate. Knock-in fixing with dowels $\text{\O}10\text{mm}$. Independent vertical adjustment.

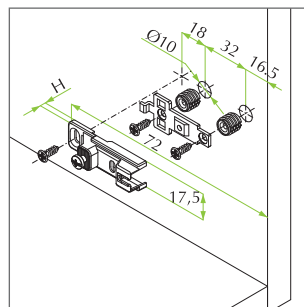

<u>Height</u>	<u>Material</u>	<u>Code</u>
<u>H=2</u>	<u>Zamak</u>	<u>52.0210.05.02.1</u>

Metal mounting plate. Selftapping screw fixing. Vertical adjustment.
Screws are provided on demand.

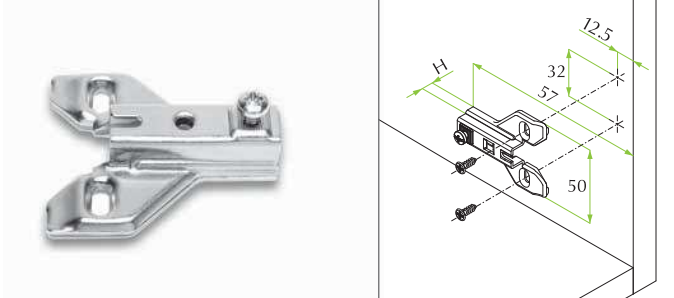

Height	Material	Code
H=2	Steel	52.0232.M5.02.1
H=5	Zamak	52.0232.05.05.1

Zamak cruciform mounting plate. Selftapping screw fixing. Vertical adjustment.
Screws are provided on demand.

37

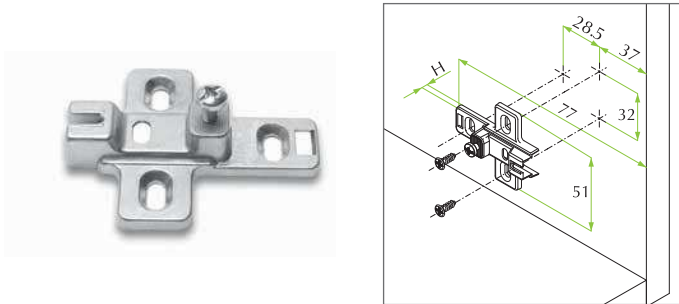

All applications are available on demand.

Zamak cruciform mounting plate. Selftapping screw fixing. Vertical adjustment.
Screws are provided on demand.

28

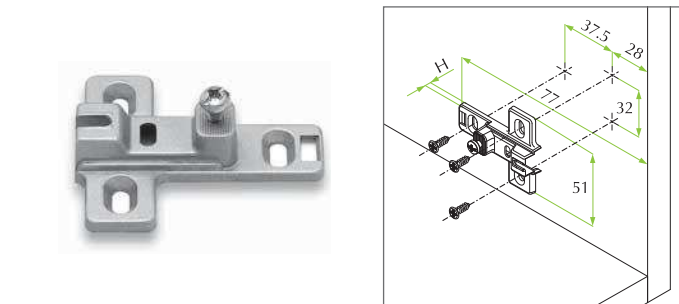

All applications are available on demand.

Spacer for mounting plates.

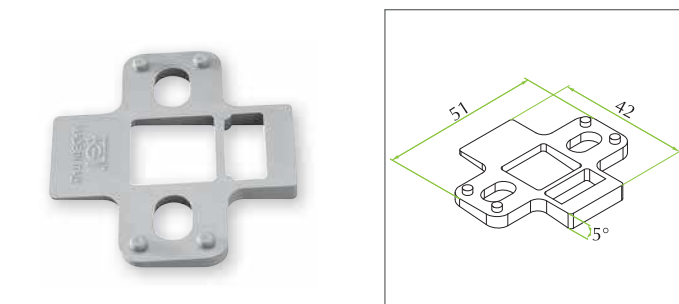

Material	Code
Nylon	52.0SP6.06.05.000

Stackable to get multiples of 5°.

Series MS Slide-On

Round face plate for glass door hinge.



Colour	Code
Bright chrome	51.0150.05.01R.00
Matt chrome	51.0150.0G.01R.00
Bright gold	51.0150.04.01R.00
Black painted	51.0150.08.01R.00
Black RAL 9005	51.0150.0T.01R.00
White RAL 9016	51.0150.01.01R.00
Metallized bright chrome	51.0150.0K.01R.00
Metallized bright gold	51.0150.0H.01R.00
Matt chrome painted	51.0150.0J.01R.00
Matt nickel	51.0150.06.01R.00

Oval face plate for glass door hinge.



Colour	Code
Bright chrome	51.0150.05.01D.00
Matt chrome	51.0150.0G.01D.00
Bright gold	51.0150.04.01D.00
Black painted	51.0150.08.01D.00
Black RAL 9005	51.0150.0T.01D.00
White RAL 9016	51.0150.01.01D.00
Metallized bright chrome	51.0150.0K.01D.00
Metallized bright gold	51.0150.0H.01D.00
Matt chrome painted	51.0150.0J.01D.00
Matt nickel	51.0150.06.01D.00

Plastic or Steel hinge arm cover.



Material	Code
Plastic	51.0M.00010.0000
Steel	51.0Y.00050.000N
Steel with FGV Logo*	51.0YFGV.5.0000000

*Customer logo on demand

Steel cover for hinge box.



Cup hole dist.	Material	Code
48-45	Steel	510C000500000
52	Steel	510C000500B00

Ø35mm cover.



Material	Code
Nylon	5307C3**00000

** Colour code: A1 = White RAL 9010 / A2 = Brown RAL 8016 / C6 = Grey RAL 7004 / OI = Painted matt aluminium

Selftapping screws with Pozi drive head, nickel for hinge and mounting plate fixing.

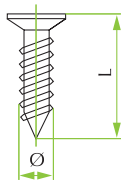

Ø	Length	Material	Code
4	12.5	Steel	1A035034150CF
4	15.5	Steel	1A035034250CF

Euro screws with Pozi drive head, nickel for mounting plate fixing.

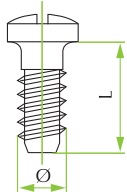

Ø	Length	Material	Code
6.3	10	Steel	1A075029350CF
6.3	12	Steel	1A075108250CF
6.3	14	Steel	1A075108150CF

Euro screws with Pozi drive head, nickel for hinge fixing.

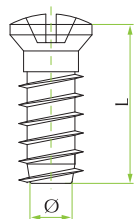

Ø	Length	Material	Code
6.3	12	Steel	1A075130050CF

Dowel in nylon for hinge fixing.

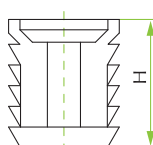

Ø	Height	Material	Code
10	12	Nylon	2H011070530CF
8	11	Nylon	2H000449003CF



QS Mini

The right size

Low depth cup for thin doors

Wide range 3D door adjustment

Large range of cup-fixing methods

Complete range of hinges & mounting plates

QS Mini hinges with Ø26mm cup size are compact, performing and cost efficient. The small size allows the use on extra thin doors, but the performance is good enough to cover also standard doors in all usual sizes. QS mini-hinges are the perfect solution for bathroom, bedroom and living room applications with entry level to mid-level specifications. With pre-mounted euro-screws or self-taping screws, they are the perfect flat-pack furniture hinge.

QS Mini

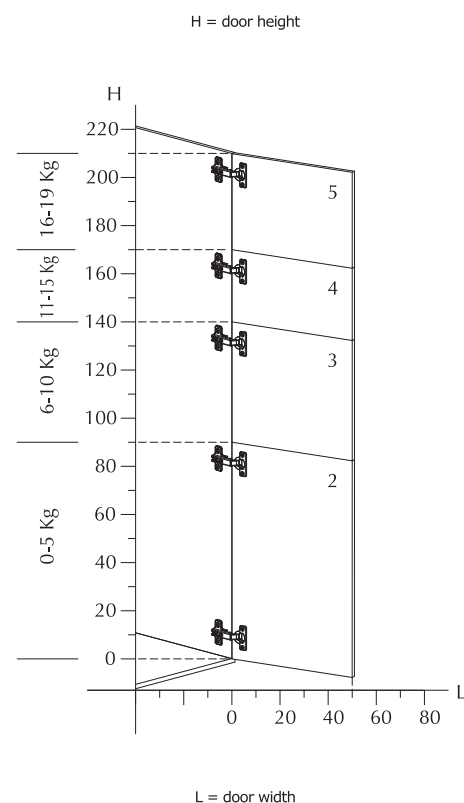

Mounting System



1 Place the rear part of the hinge on the front side of the mounting plate.



2 Let the hinge slide on the mounting plate until it stops.



3 Tighten the connecting screw.

Adjusting System

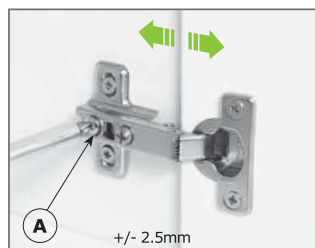

Front adjustment
Acting on the "A" screw it is possible to adjust the distance between the side of the cabinet and the door.

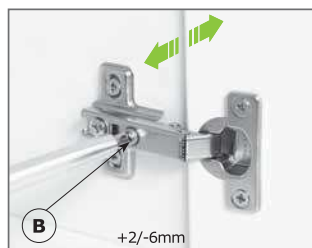

Independent side adjustment
Acting on the "B" screw it is possible to change the amount of the door covering on the side of the cabinet.

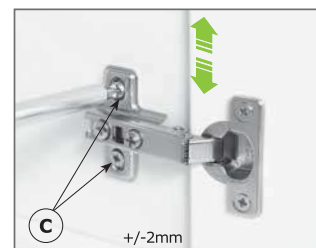

Vertical adjustment
Acting on the "C" screw of the mounting plate it is possible to adjust the door vertically.

FOR WOOD DOORS
105° Ø26



Summary table p. 112

Product detail p. 114

FOR WOOD CORNER
90°



Summary table p. 112

Product detail p. 116

SPECIAL SOLUTIONS

FOR GLASS DOORS
105° Ø26



Summary table p. 113

Product detail p. 118

FOR GLASS CORNER
90°



Summary table p. 113

Product detail p. 120

FOR DOORS WITH
ALUMINIUM FRAME
105°



Summary table p. 113

Product detail p. 122

ZIP FIXING
SYSTEM



Summary table p. 113

**Cup hole distance
38x8mm**

M

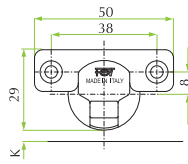

FOR WOOD DOORS 105° Ø26



Crank 0		p. 114	p. 114	p. 114	p. 114	p. 114
Crank 8		p. 114	p. 114	p. 114	p. 114	p. 114
Crank 15		p. 114	p. 114	p. 114	p. 114	p. 114

FOR WOOD CORNER DOORS 90°

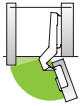

Angle 24°÷30°		p. 116	p. 116	p. 116	p. 116	p. 116
Angle 45°		p. 116	p. 116	p. 116	p. 116	p. 116
Angle 90°		p. 116	p. 116	p. 116	p. 116	p. 116



SELF TAPPING SCREW

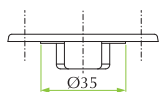

EURO SCREW

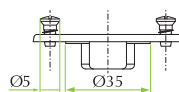

DOWEL

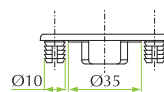

VELOFIX DOWEL

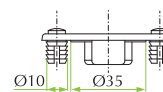

X-PANDO DOWEL

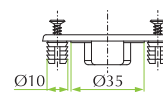

SPECIAL SOLUTIONS

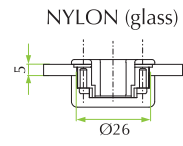
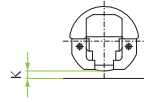

FOR GLASS DOORS OPENING 105° Ø26



Crank 0		p. 118
Crank 8		p. 118
Crank 15		p. 118

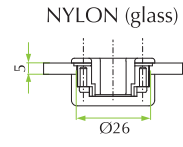
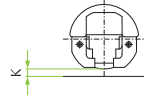

FOR CORNER CABINET - GLASS OPENING 90°



Angle 24°÷30°		p. 120
Angle 45°		p. 120
Angle 90°		p. 120

LOCK FIXING

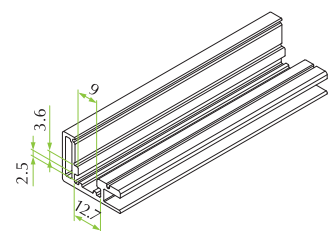

FOR DOORS WITH ALUMINIUM FRAME OPENING 105°

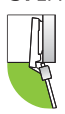

Crank 0		p. 122
Crank 8		p. 122
Crank 15		p. 122

ZIP FIXING SYSTEM

The Zip dowels allow a no-tool mounting of the hinge.

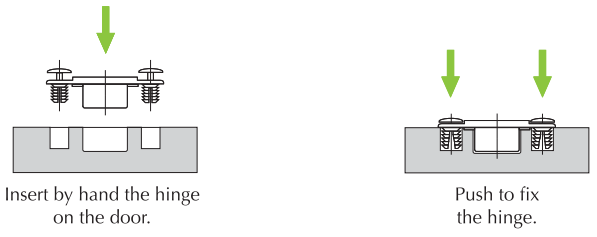

The hinges with Zip fixing system are available on demand. Please contact the FGV Customer Service.

QS Mini 105° Ø26 for wood doors



Technical specifications:

- Depth of the metal cup 9.8mm
- Cup diameter 26mm
- Opening 105° with (K) max 4mm and (T) max 18mm
- Possibility of door drilling (K) from 3 to 6 mm
- Thickness of the door (T) from 12 to 26 mm

CRANK 0

CRANK 8

CRANK 15



M

51.QS15.05.00.02000

51.QS15.05.08.0200

51.QS15.05.15.02000

Available with premounted selftapping screws



M

51.QS16.05.00.M2000

51.QS16.05.08.M2000

51.QS16.05.15.M2000



M

51.QS16.05.00.*2000

51.QS16.05.08.*2000

51.QS16.05.15.*2000

* 0 = dowels Ø10mm / D = dowels Ø8mm



M

51.QS18.05.00.V2000

51.QS18.05.08.V2000

51.QS18.05.15.V2000



M

51.QS19.05.00.*2052

51.QS19.05.08.*2052

51.QS19.05.15.*2052

* 0 = dowels Ø10mm / D = dowels Ø8mm

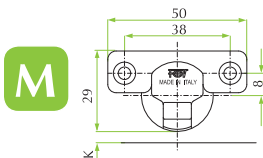

The mounting plates and fittings for this series are shown from page 124 to page 127.

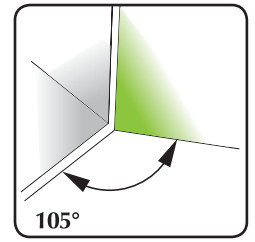
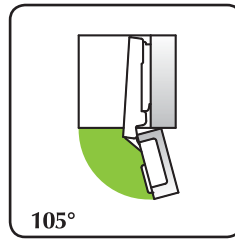

CRANK 0
For lay-on doors

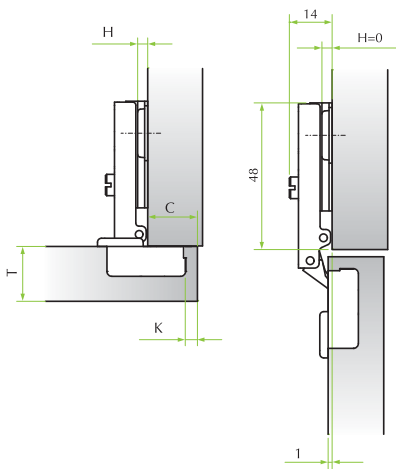

CRANK 8
For partial lay-on doors

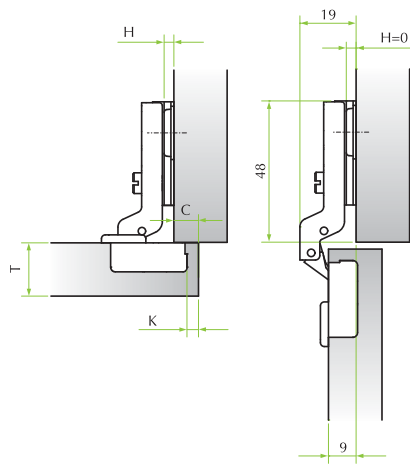

CRANK 15
For inset doors

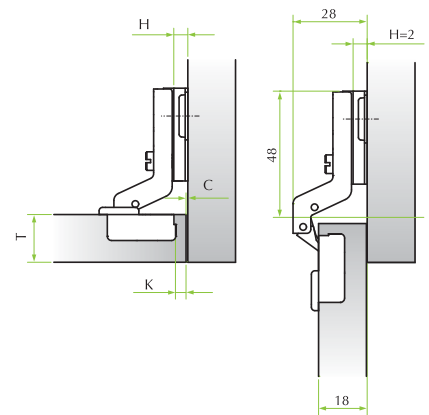

		Drilling distance (K)							
		3	4	5	6				
Overlay (C)	19				0				
	18			0					
	17		0		2				
	16	0		2					
	15		2		4				
	14			4		6			
	13				4		6		
	12					4		6	
	11						4		6
10							4		
		Mounting plates (H)							

		Drilling distance (K)							
		3	4	5	6				
Overlay (C)	11				0				
	10				0				
	9			0		2			
	8		0		2				
	7			2		4			
	6				2		4		
	5					2		4	
	4						2		4
	3							2	
2								2	
		Mounting plates (H)							

		Drilling distance (K)							
		3	4	5	6				
Overlay (C)	0		2		4				
	1			2		4			
	2				2		4		
	3					2		4	
	4						2		4
	5							2	4
		Mounting plates (H)							

Table to determinate the minimum distance **A** so that a door with **T** thickness can open without protrusion from the cabinet and without interfering with adjacent doors.

	T=	16	17	18	19	20	21	22	23	24	25	26
K=3	A=	1.60	2.25	3.0	3.85	4.70	5.60	6.50	7.40	8.35	9.30	10.20
K=4	A=	1.55	2.10	2.75	3.50	4.30	5.15	6.00	6.90	7.80	8.70	9.65
K=5	A=	1.45	1.90	2.50	3.15	3.90	4.70	5.50	6.35	7.25	8.15	9.05
K=6	A=	1.40	1.80	2.30	2.90	3.55	4.30	5.10	5.90	6.75	7.60	8.50

QS Mini 90° for wood corner doors



Technical specifications:

- Depth of the metal cup 11.7mm
- Cup diameter 26mm
- Opening 90°
- Possibility of door drilling (K) from 3 to 5 mm
- Thickness of the door (T) from 12 to 26 mm

ANGLE 24°÷30°

ANGLE 45°

ANGLE 90°



M

51.QS15.05.24.00000

51.QS15.05.45.00000

51.QS15.M5.90.02000

Available with premounted selftapping screws



M

51.QS16.05.24.M0000

51.QS16.05.45.M0000

51.QS16.M5.90.M2000



M

51.QS16.05.24.*2000

51.QS16.05.45.*2000

51.QS16.M5.90.*2000

* 0 = dowels Ø10mm / D = dowels Ø8mm



M

51.QS18.05.24.V0000

51.QS18.05.45.V0000

51.QS18.M5.90.V2000



M

51.QS19.05.24.*0052

51.QS19.05.45.*0052

51.QS19.M5.90.*2052

* 0 = dowels Ø10mm / D = dowels Ø8mm

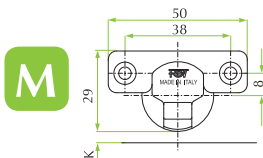

The mounting plates and fittings for this series are shown from page 124 to page 127.

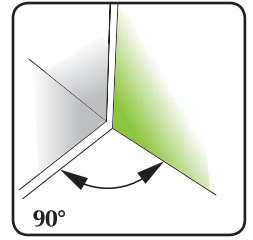
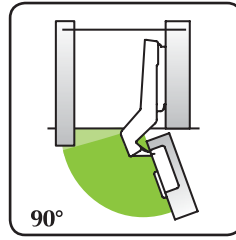

ANGLE 24°÷30°

ANGLE 45°

ANGLE 90°

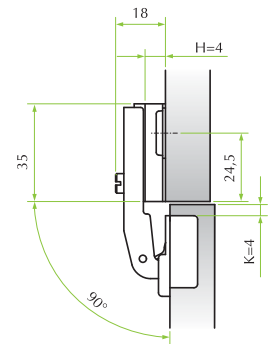
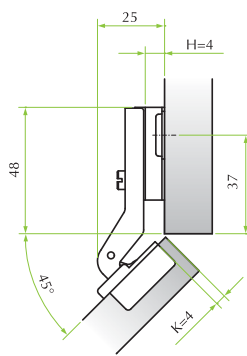
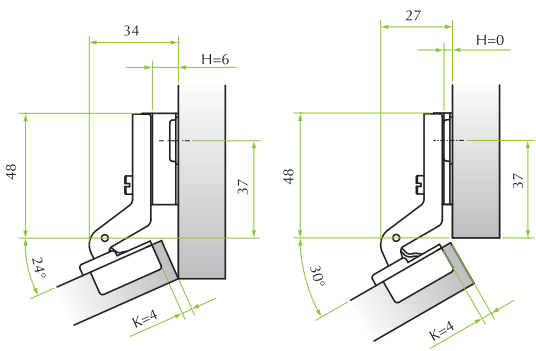

QS Mini 105° for glass doors



Technical specifications:

- Nylon cup
- Cup diameter 26mm
- Opening 105°
- Possibility of door drilling (K) from 3 to 6 mm
- Thickness of the glass door (T) from 4 to 5 mm

CRANK 0

CRANK 8

CRANK 15

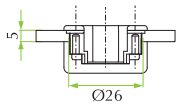

NYLON
(glass)



51.QS51.2*.00.0200



51.QS51.2*.08.0200



51.QS51.2*.15.0200

* 1 = White / 3 = Black

NYLON (glass)

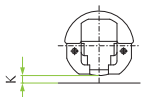

The mounting plates and fittings for this hinge series are shown from page 124 to page 127.

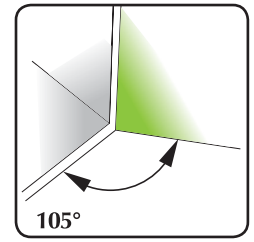
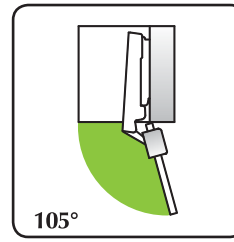

CRANK 0
For lay-on doors

CRANK 8
For partial lay-on doors

CRANK 15
For inset doors

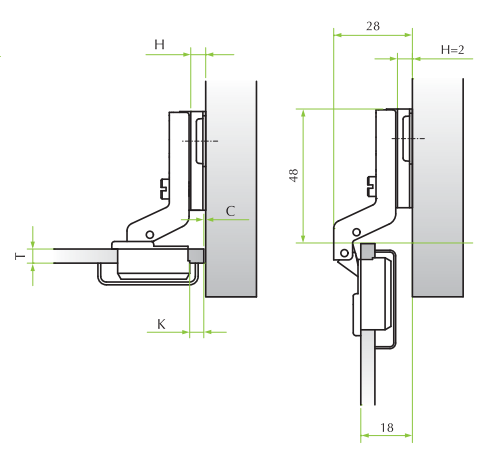
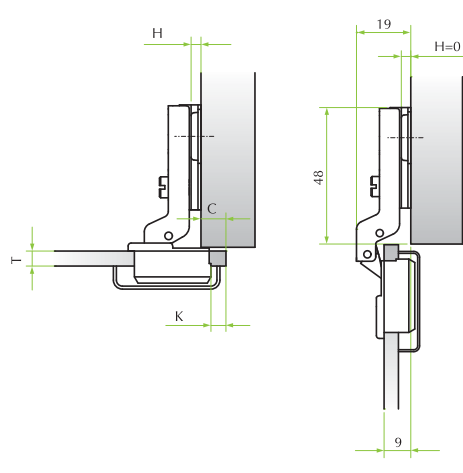
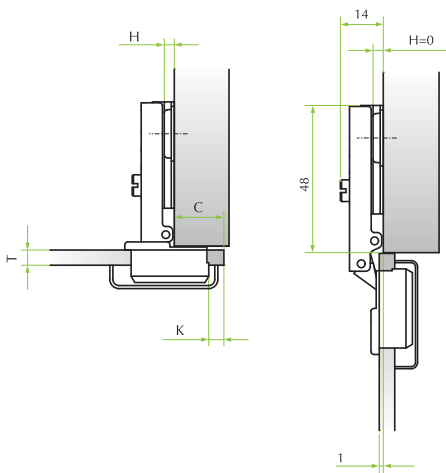

		Drilling distance (K)								
		3	4	5	6					
Overlay (C)	19				0					
	18			0						
	17		0	2						
	16	0	2							
	15	2	4							
	14	4	6							
	13	6								
	12									
	11									
10										
		Mounting plates (H)								

		Drilling distance (K)								
		3	4	5	6					
Overlay (C)	11				0					
	10			0						
	9		0	2						
	8	0	2							
	7	2	4							
	6	4	6							
	5	6								
	4									
	3									
	2									
			Mounting plates (H)							

		Drilling distance (K)								
		3	4	5	6					
Overlay (C)	0		2	4						
	1	2	4							
	2	4	6							
	3	6								
	4									
	5									
		Mounting plates (H)								

QS Mini 90° for glass corner doors



Technical specifications:

- Nylon cup
- Cup diameter 26mm.
- Opening 90°
- Possibility of door drilling (K) from 3 to 5 mm.
- Thickness of the glass door (T) from 4 to 5 mm.

	ANGLE 24°÷30°	ANGLE 45°	ANGLE 90°
 <p>NYLON (glass)</p>			
N	51.QS51.2*.24.0000	51.QS51.2*.45.0000	51.QS51.2*.90.0000
	* 1 = White / 3 = Black		

NYLON (glass)

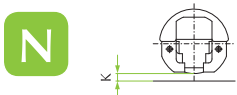

The mounting plates and fittings for this hinge series are shown from page 124 to page 127.

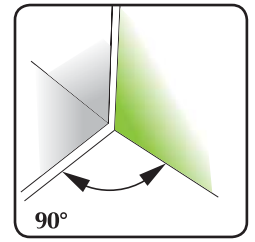
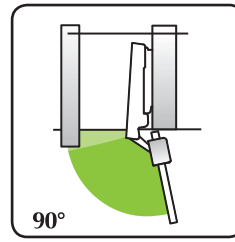

ANGLE 24°±30°

ANGLE 45°

ANGLE 90°

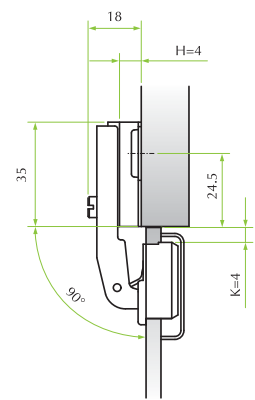
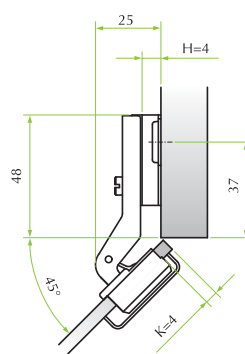
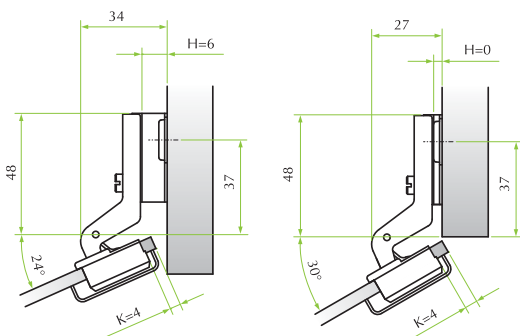

QS Mini 105° for doors with aluminium frame



Technical specifications:

- Opening 105°
- Aluminium frame (K) min. 3 to 6 mm

LOCK FIXING

CRANK 0



51.QS31.05.00.02000

CRANK 8



51.QS31.05.08.02000

CRANK 15



51.QS31.05.15.02000

Aluminium frame:

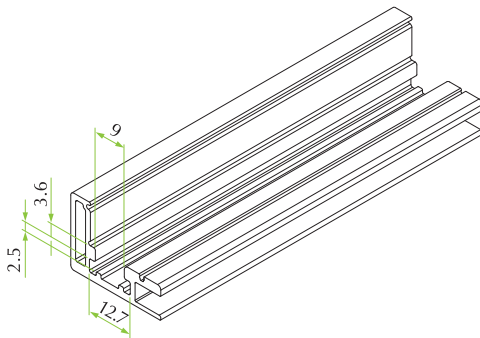

Assembly instructions:

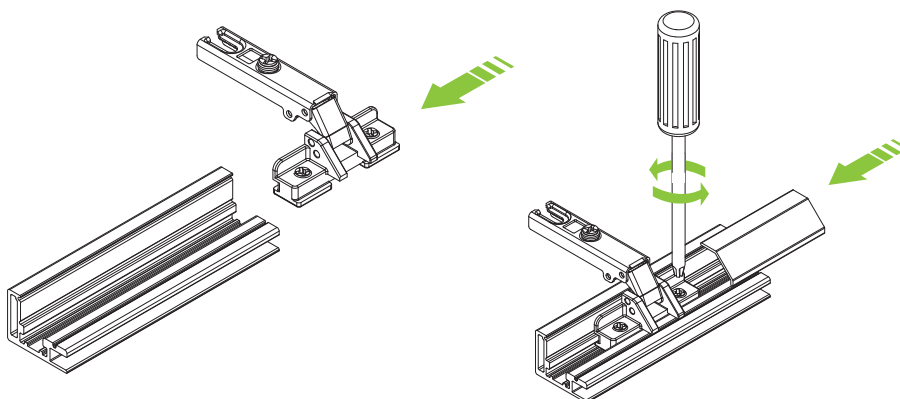

The mounting plates and fittings for this hinge series are shown from page 124 to page 127.

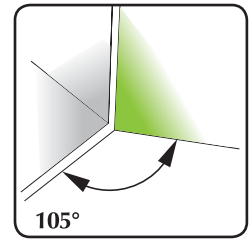
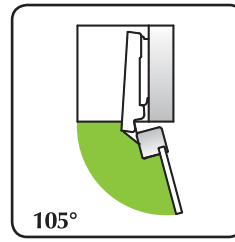

CRANK 0
For lay-on doors

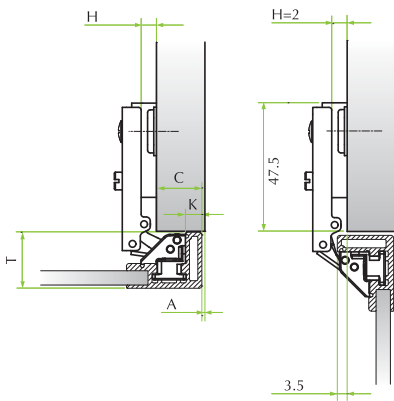

CRANK 8
For partial lay-on doors

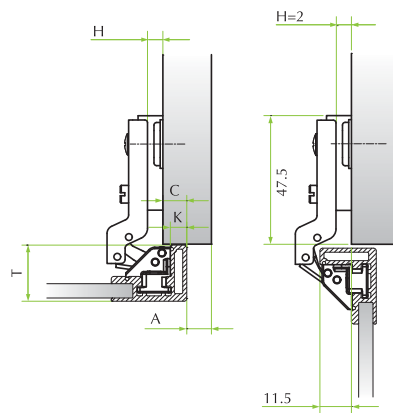

CRANK 15
For inset doors

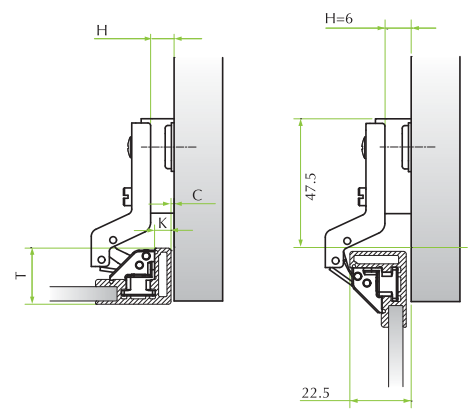

		Drilling distance (K)							
		3	4	5	6				
Overlay (C)	19				0				
	18			0					
	17		0	2					
	16	0	2						
	15	2	4						
	14	4	6						
	13	6							
	12								
	11								
10									
		Mounting plates (H)							

		Drilling distance (K)							
		3	4	5	6				
Overlay (C)	11				0				
	10			0					
	9		0	2					
	8	0	2						
	7	2	4						
	6	4	6						
	5	6							
	4								
	3								
	2								
			Mounting plates (H)						

		Drilling distance (K)							
		3	4	5	6				
Overlay (C)	0		2	4					
	1	2	4						
	2	4	6						
	3	6							
	4								
	5								
		Mounting plates (H)							

Metal cruciform mounting plate. Selftapping screw fixing. Vertical adjustment.

Screws are provided on demand.

37

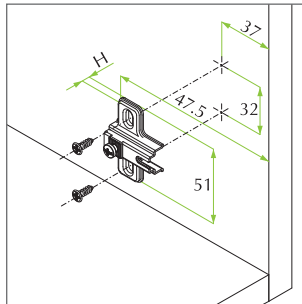

Height	Material	Code
H=0	Steel	52.0301.M5.00.1
H=2	Steel	52.0301.M5.02.1
H=4	Steel	52.0301.M5.04.1
H=6	Steel	52.0301.M5.06.1

Metal cruciform mounting plate. Euro screws premounted. Vertical adjustment.

37

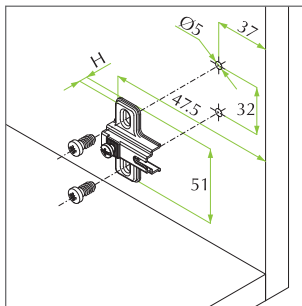

Height	Material	Code
H=0	Steel	52.0316.M5.00.*
H=2	Steel	52.0316.M5.02.*
H=4	Steel	52.0316.M5.04.*
H=6	Steel	52.0316.M5.06.*

* C = D = H =

Metal cruciform mounting plate. Premounted selftapping screws Ø4.7mm. Vertical adjustment.

37

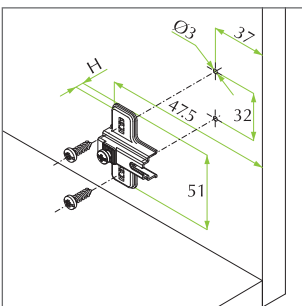

Height	Material	Code
H=0	Steel	52.03G5.M5.00.1
H=2	Steel	52.03G5.M5.02.1
H=4	Steel	52.03G5.M5.04.1
H=6	Steel	52.03G5.M5.06.1

Metal cruciform mounting plate. Fixing by expanding X-Pando dowels Ø5mm. Vertical adjustment.

37

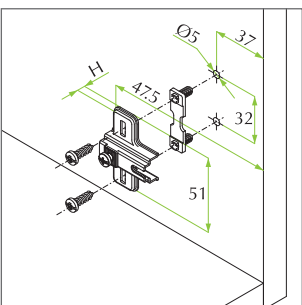

Height	Material	Code
H=0	Steel	52.03N5.M5.00.*
H=2	Steel	52.03N5.M5.02.*
H=4	Steel	52.03N5.M5.04.*
H=6	Steel	52.03N5.M5.06.*

* 1 = 3 =

Metal cruciform mounting plate. Knock-in fixing with dowels Ø8mm. Vertical adjustment.

37

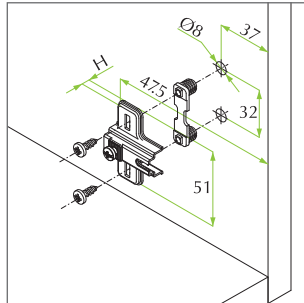

Height	Material	Code
H=0	Steel	52.03*5.M5.00.1
H=2	Steel	52.03*5.M5.02.1
H=4	Steel	52.03*5.M5.04.1
H=6	Steel	52.03*5.M5.06.1

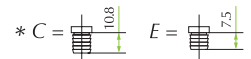

Metal cruciform mounting plate. Knock-in fixing with dowels Ø10mm. Vertical adjustment.

37

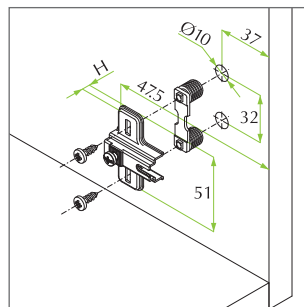

Height	Material	Code
H=0	Steel	52.03*5.M5.00.1
H=2	Steel	52.03*5.M5.02.1
H=4	Steel	52.03*5.M5.04.1
H=6	Steel	52.03*5.M5.06.1

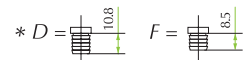

Metal cruciform mounting plate. Euro screws premounted. Vertical adjustment.

28

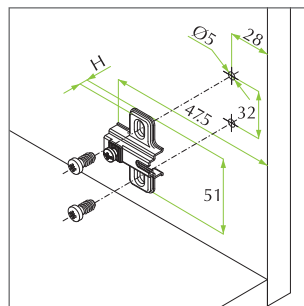

Height	Material	Code
H=2	Steel	52.0321.M5.02.*

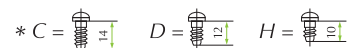

Metal cruciform mounting plate. Premounted selftapping screws Ø4.7mm. Vertical adjustment.

28

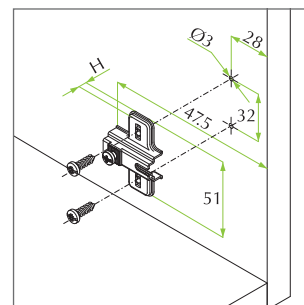

Height	Material	Code
H=2	Steel	52.03G1.M5.02.1

Metal mounting plate. Fixing by expanding X-Pando dowels Ø5mm. Vertical adjustment.

28

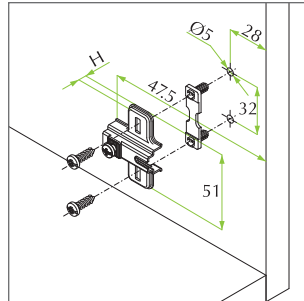

Height	Material	Code
H=2	Steel	52.03N1.M5.02.1

Metal cruciform mounting plate. Knock-in fixing with dowels Ø8mm. Vertical adjustment.

28

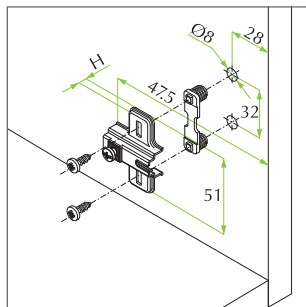

Height	Material	Code
H=2	Steel	52.03*1.M5.02.1

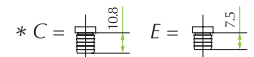

Metal cruciform mounting plate. Knock-in fixing with dowels Ø10mm. Vertical adjustment.

28

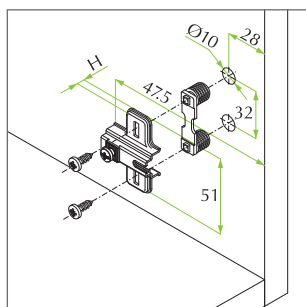

Height	Material	Code
H=2	Steel	52.03*1.M5.02.1

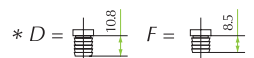

Euro screws with Pozi drive head, nickel for mounting plate fixing.

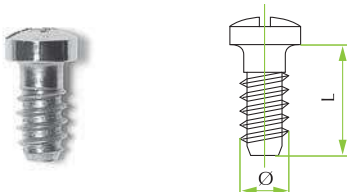

Ø	Length	Material	Code
6.3	10	Steel	1A075029350CF
6.3	12	Steel	1A075108250CF
6.3	14	Steel	1A075108150CF

Round face plate for glass door hinge.



Colour	Code
Bright chrome	51.0150.05.01R.00
Matt chrome	51.0150.0G.01R.00
Bright gold	51.0150.04.01R.00
Black painted	51.0150.08.01R.00
Black RAL 9005	51.0150.0T.01R.00
White RAL 9016	51.0150.01.01R.00
Metallized bright chrome	51.0150.0K.01R.00
Metallized bright gold	51.0150.0H.01R.00
Matt chrome painted	51.0150.0J.01R.00
Matt nickel	51.0150.06.01R.00

Oval face plate for glass door hinge.



Colour	Code
Bright chrome	51.0150.05.01D.00
Matt chrome	51.0150.0G.01D.00
Bright gold	51.0150.04.01D.00
Black painted	51.0150.08.01D.00
Black RAL 9005	51.0150.0T.01D.00
White RAL 9016	51.0150.01.01D.00
Metallized bright chrome	51.0150.0K.01D.00
Metallized bright gold	51.0150.0H.01D.00
Matt chrome painted	51.0150.0J.01D.00
Matt nickel	51.0150.06.01D.00

Selftapping screws with Pozi drive head, nickel for hinge and mounting plate fixing.

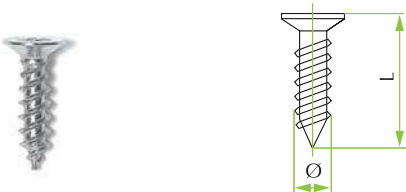

Ø	Length	Material	Code
4	12.5	Steel	1A035034150CF
4	15.5	Steel	1A035034250CF

Euro screws with Pozi drive head, nickel for hinge fixing.

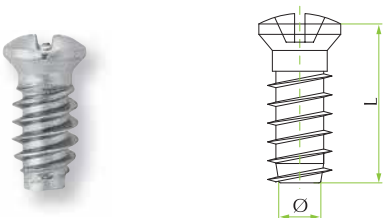

Ø	Length	Material	Code
6.3	12	Steel	1A075130050CF

Dowel in nylon for hinge fixing.

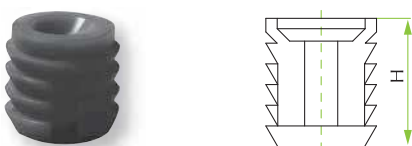

Ø	Height	Material	Code
10	12	Nylon	2H011070530CF
8	11	Nylon	2H000449003CF