

# FECHADURA MECÂNICA

MECHANICAL LOCK | SERRURE MECANIQUE | MECHANISCHE SCHLÖSER

QM50

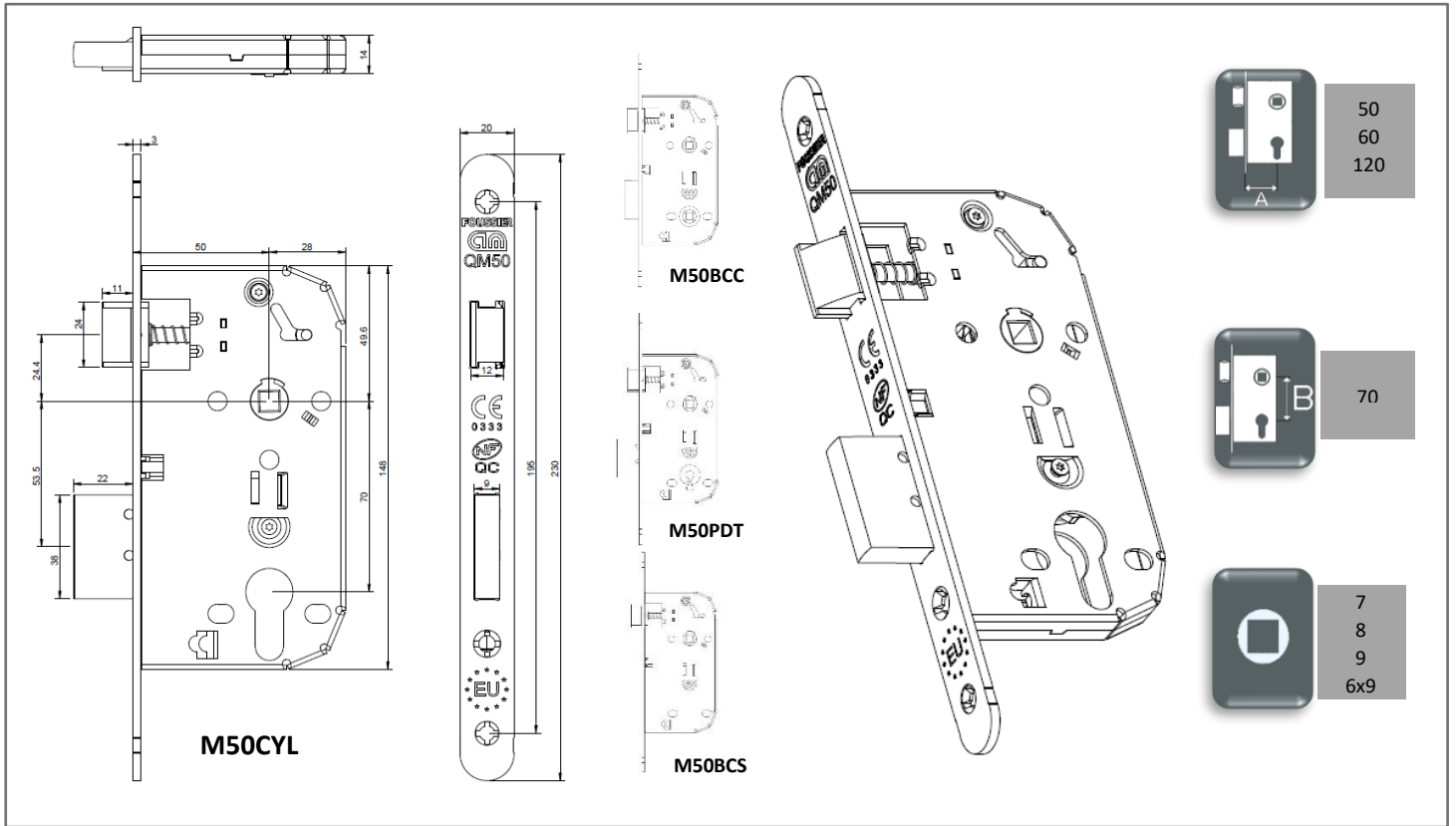

## Características · Feature · Caractéristiques · Eigenschaften



Furos de Roseta  
Rosette holes  
Trous de rosaces  
Rosettenbohrungen



Reversível  
Non handed  
Réversible  
Beidseitig verwendbar



Corta Fogo  
Fire Doors  
Coupe-feu  
Für Feuerschutzabschluss



Chave aciona o trinco  
Key action on latch bolt  
Avec fonction équerre  
Wechsélfunktion



2 Voltas  
2 Throws  
2 Tours de clé  
2 Zwitourig



Topos redondos/quadrados  
Round/ Square frontplate  
Tête/bouts ronds/ carrés  
Eckige oder runde Stulpe



Chapa testa opcional  
Strike plate optional  
Gâche en option  
Schließblech optional



Embalagem de 25 peças  
Packing -25 pieces per box  
Carton de 25 pièces  
25 Einheiten pro Karton



8 Variedades de chave  
8 Different keys  
8 Variure de clés  
8 Schlüsselschweifungen

1 / 1

+351 234 690 400 | [www.amlocks.pt](http://www.amlocks.pt) | [info@amlocks.pt](mailto:info@amlocks.pt)

Documento não contratual: AM reserva-se o direito de alterar os seus produtos com o objetivo de melhoria contínua

P2-FT501-A

P2-F4-A