

LUNCH

ISTRUZIONI DI MONTAGGIO ASSEMBLY INSTRUCTIONS

MODELLI
MODELS:

411/78.1105.22E - LUNCH 450
411/78.1100.22E - LUNCH 600
411/78.1110.22E - LUNCH 900
411/78.1120.22E - LUNCH 1200

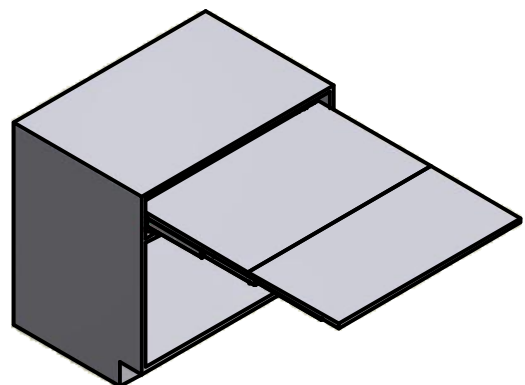

CONTENUTO DELLA CONFEZIONE INCLUDED IN THE PACKAGING

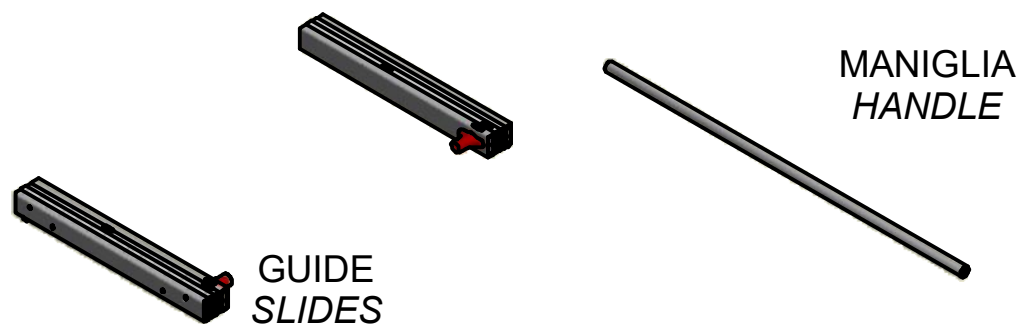

SACCHETTO ACCESSORI - ACCESSORIES

- A. Chiave esa. da 5 - n° 5 Allen key (x 1)
- B. Chiave esa. da 4 - n° 4 Allen key (x 1)
- C. Bussola M6 - M6 bush (x 12)
- D. Vite TCCE M6x12 - M6x12 SHCS screw (x 8)
- E. Vite TCCE M6x60 - M6x60 SHCS screw (x 4)

DIMENSIONI GENERALI GENERAL DIMENSIONS

DIMENSIONE - DIMENSION	SIMBOLO - SYMBOL	mm
ALTEZZA - HEIGHT	H	MIN: 120
PROFONDITA' - DEPTH	P	MIN: 540
LARGHEZZA - WIDTH	L	MIN: 410 MAX: 1170
SPESSORI - THICKNESS	S	MIN: 16
SPESSORI SPALLE - SIDE THICKNESS	S1	15-20
LARGHEZZA - WIDTH	Z	L-5
APERTURA - OPENING	E	895
APERTURA MECCANISMO - MECHANISM OPENING	C	773

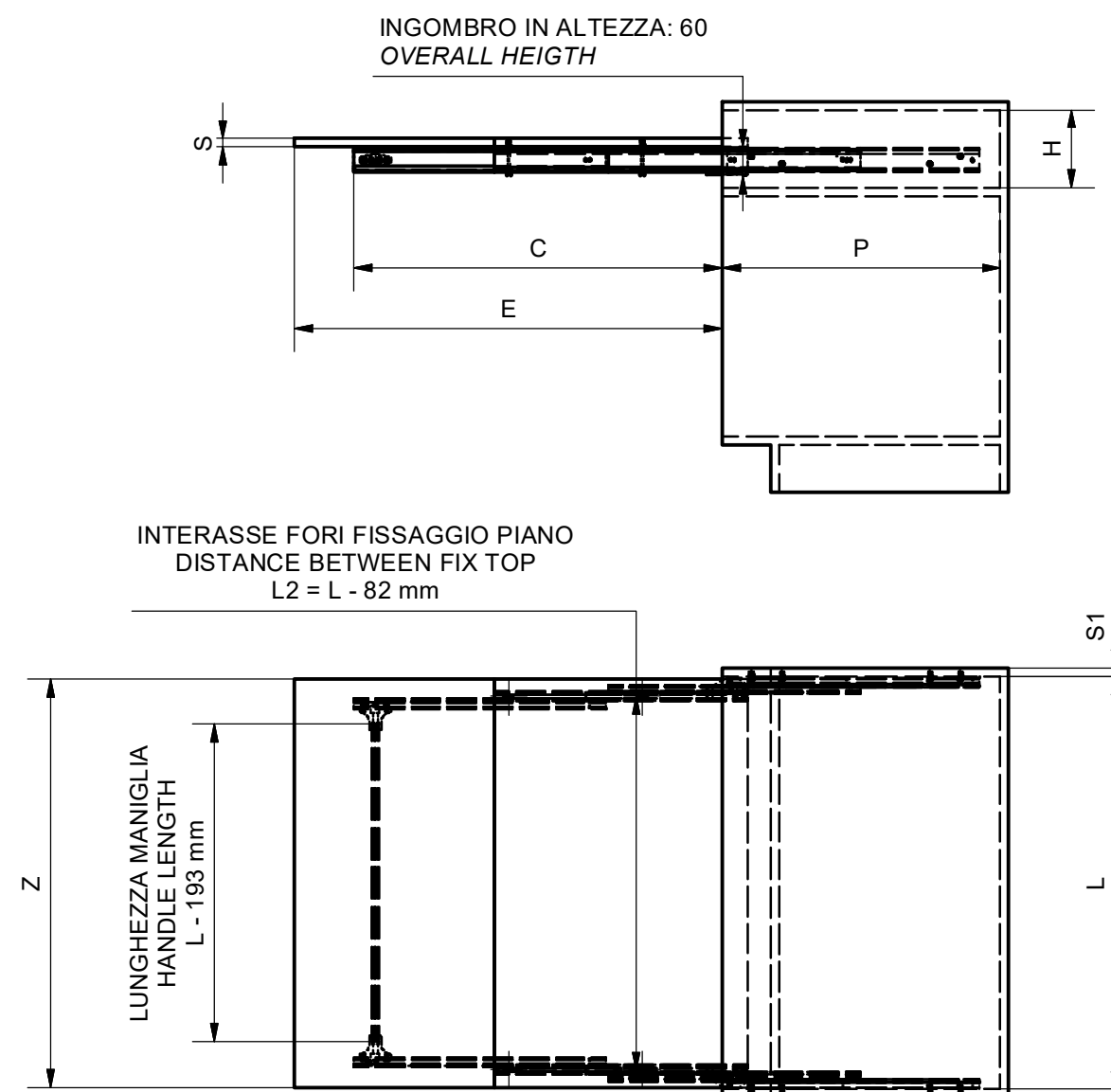

FORI FISSAGGIO MECCANISMO HOLES FOR MECHANISM

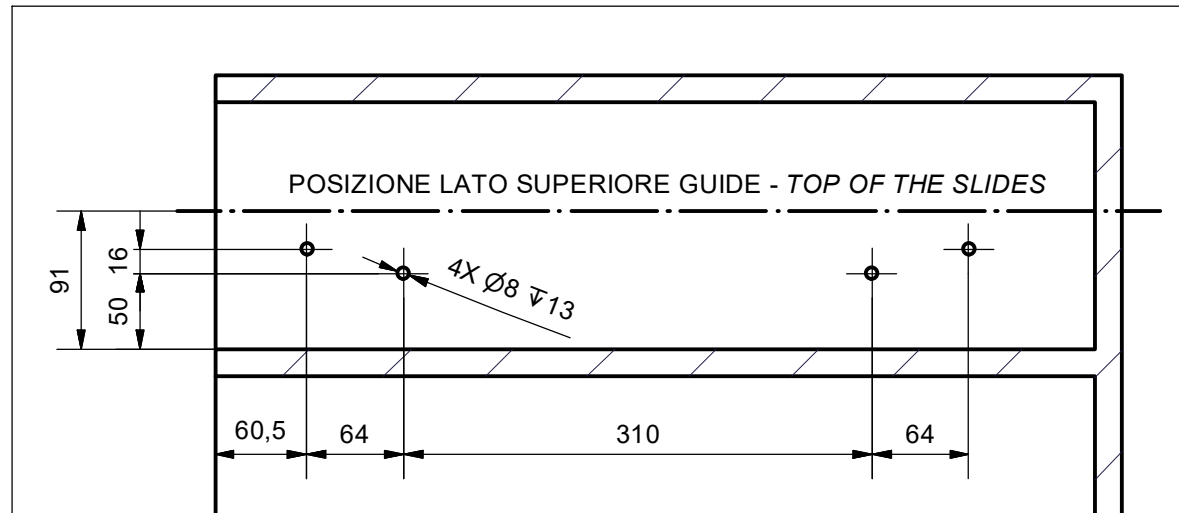

DIMENSIONI PIANO TOP DIMENSIONS

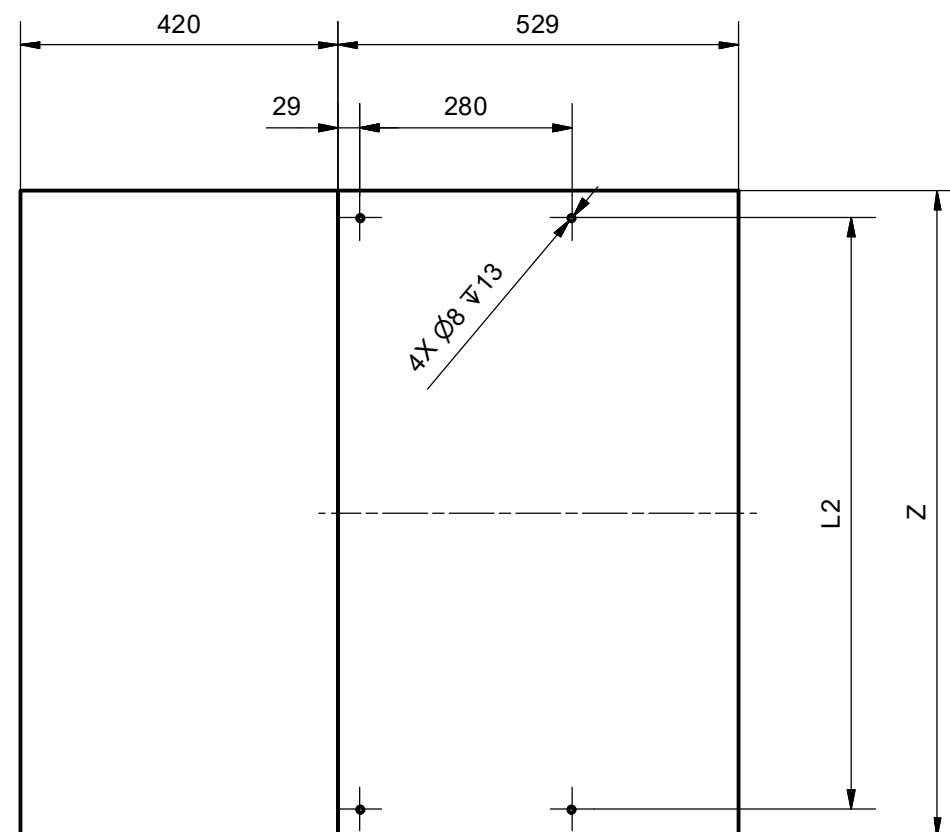

MONTAGGIO DEL MECCANISMO MOUNTING OF THE MECHANISM

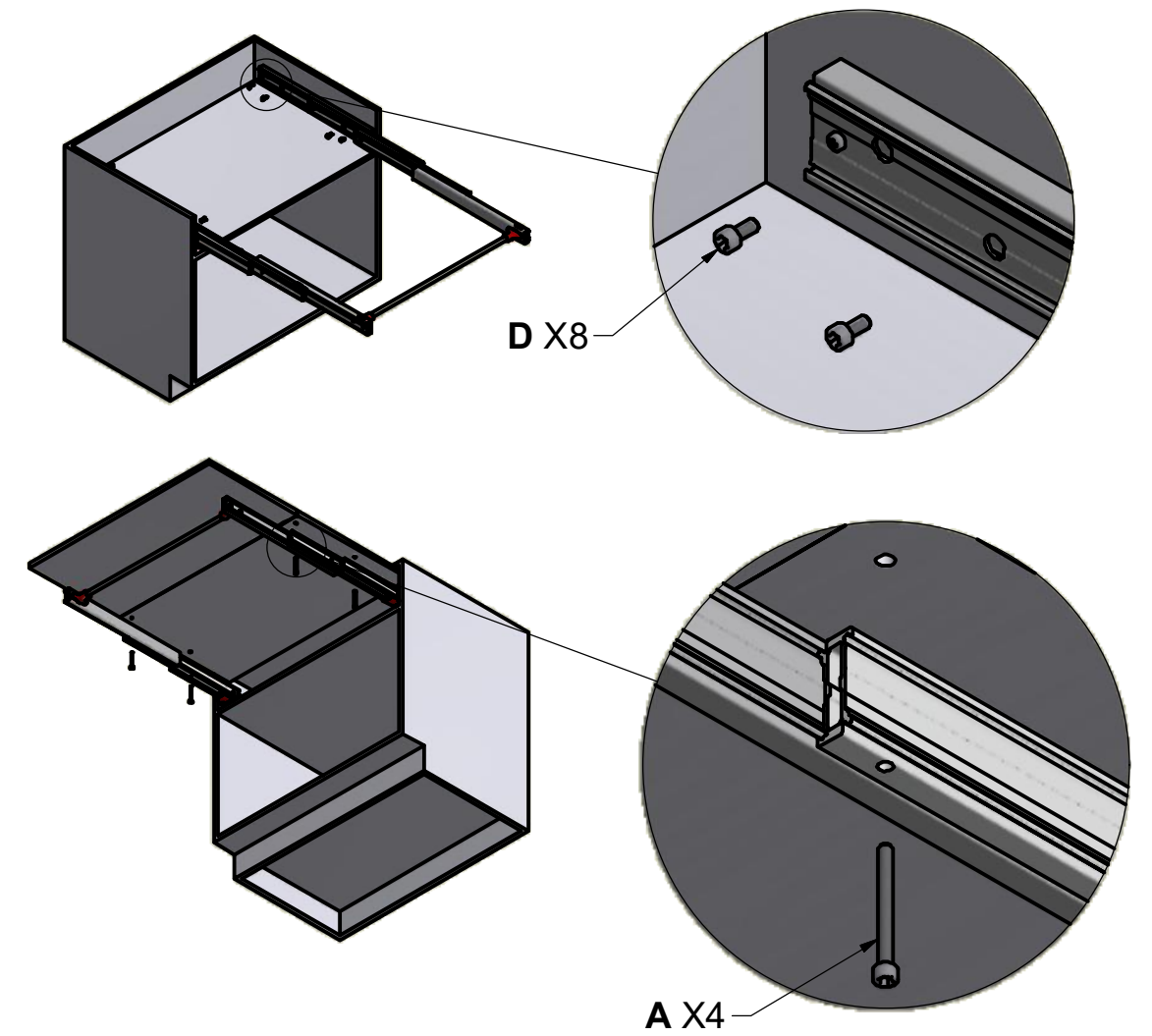

SEQUENZA DI FUNZIONAMENTO FUNCTIONING STEPS

